

SETUP & OPERATION MANUAL

FEATURES

- **New!** Upper and lower blade guard assembly helps prevent unintentional or accidental hand/finger contact with the saw blade
- **New!** Switch protection device to prevent accidental or unintentional start-up of the saw.
- **New!** Dust collector table kit for direct dust-extraction hook-up.
- Head tilts 30° (EX-16) / 38° (EX-21 & EX30) left and 45° right, tilting the blade, not the table keeping the workpiece level for better control & more accurate cuts.
- 2" cutting thickness capacity.
- Quick blade changes with finger operated blade clamps, no tools required.
- Easy access speed and tension controls.
- Onboard dust blower.
- **EX-16**
16" throat capacity. Large 12" x 18 1/2" (305 x 470 mm) table surface.
- **EX-21**
21" throat capacity. Large 13 1/2" x 23 1/2" (345 x 597 mm) table surface. Organized blade storage on base.
- **EX-30**
30" throat capacity. Large 14" x 32 1/2" (358 x 825 mm) table surface. Organized blade storage on base.

SPECIFICATIONS

LENGTH

27" (686 mm) - **EX-16**
32" (812 mm) - **EX-21**
43 1/4" (1100 mm) - **EX-30**

WIDTH

15" (380 mm) - **EX-16 & EX-21**
15 1/2" (394 mm) - **EX-30**

HEIGHT

17" (432 mm) - **EX-16**
15" (380 mm) - **EX-21**
15 1/4" (387 mm) - **EX-30**

BLADE TILT RANGE

30° (LEFT) TO 45° (RIGHT) - **EX-16**
38° (LEFT) TO 45° (RIGHT) - **EX-21 & EX-30**

THROAT

16" (406 mm) - **EX-16**
21" (535 mm) - **EX-21**
30" (762 mm) - **EX-30**

MAXIMUM CUTTING DEPTH

2" (51 mm)

SPEED (VARIABLE)

400 TO 1400 STROKES/MIN - **EX-16**
400 TO 1550 STROKES/MIN - **EX-21 & EX-30**

TABLE SURFACE

12" x 18 1/2" (305 x 470 mm) - **EX-16**
13 1/2" x 23 1/2" (345 x 597 mm) - **EX-21**
14" x 32 1/2" (358 x 825 mm) - **EX-30**

MOTOR

120 V, 1.3 A

WEIGHT

54 LBS (24.5 kg) - **EX-16**
65 LBS (29.5 kg) - **EX-21**
97 LBS (44 kg) - **EX-30**

SCROLL SAW



MODELS

#EX-16

#EX-21

#EX-30

(MODEL #EX-21 SHOWN)





GENERAL® INTERNATIONAL

8360 Champ-d'Eau, Montreal (Quebec) Canada H1P 1Y3
Telephone (514) 326-1161 • Fax (514) 326-5555 • www.general.ca

THANK YOU for choosing this Excalibur by General® International Scroll Saw model. This scroll saw has been carefully tested and inspected before shipment and if properly used and maintained, will provide you with years of reliable service. For your safety, as well as to ensure optimum performance and trouble-free operation, and to get the most from your investment, please take the time to read this manual before assembling, installing and operating the unit

The manual's purpose is to familiarize you with the safe operation, basic function, and features of this scroll saw as well as the set-up, maintenance and identification of its parts and components. This manual is not intended as a substitute for formal woodworking instruction, nor to offer the user instruction in the craft of woodworking. If you are not sure about the safety of performing a certain operation or procedure, do not proceed until you can confirm, from knowledgeable and qualified sources, that it is safe to do so.

Once you've read through these instructions, keep this manual handy for future reference.

Disclaimer: The information and specifications in this manual pertain to the unit as it was supplied from the factory at the time of printing. Because we are committed to making constant improvements, General® International reserves the right to make changes to components, parts or features of this unit as deemed necessary, without prior notice and without obligation to install any such changes on previously delivered units. Reasonable care is taken at the factory to ensure that the specifications and information in this manual corresponds with

that of the unit with which it was supplied. However, special orders and "after factory" modifications may render some or all information in this manual inapplicable to your machine. Further, as several generations of this model of scroll saw and several versions of this manual may be in circulation, if you own an earlier or later version of this unit, this manual may not depict your unit exactly. If you have any doubts or questions contact your retailer or our support line with the model and serial number of your unit for clarification.

GENERAL® & GENERAL® INTERNATIONAL WARRANTY

All component parts of General®, General® International and Excalibur by General International® products are carefully inspected during all stages of production and each unit is thoroughly inspected upon completion of assembly.

Limited Lifetime Warranty

Because of our commitment to quality and customer satisfaction, General® and General® International agree to repair or replace any part or component which upon examination, proves to be defective in either workmanship or material to the original purchaser for the life of the tool. *However, the Limited Lifetime Warranty does not cover any product used for professional or commercial production purposes nor for industrial or educational applications. Such cases are covered by our Standard 2-year Limited Warranty only. The Limited Lifetime Warranty is also subject to the "Conditions and Exceptions" as listed below.*

Standard 2-Year Limited Warranty

All products not covered by our lifetime warranty including products used in commercial, industrial and educational applications are warranted for a period of 2 years (24 months) from the date of purchase. General® and General® International agree to repair or replace any part or component which upon examination, proves to be defective in either workmanship or material to the original purchaser during this 2-year warranty period, subject to the "conditions and exceptions" as listed below.

To file a Claim

To file a claim under our Standard 2-year Limited Warranty or under our Limited Lifetime Warranty, all defective parts, components or machinery must be returned freight or postage prepaid to General® International, or to a nearby distributor, repair center or other location designated by General® International. For further details call our service department at 1-888-949-1161 or your local distributor for assistance when filing your claim.

Along with the return of the product being claimed for warranty, a copy of the original proof of purchase and a "letter of claim" must be included (a warranty claim form can also be used and can be obtained, upon request, from General® International or an authorized distributor) clearly stating the model and serial number of the unit (if applicable) and including an explanation of the complaint or presumed defect in material or workmanship.

CONDITIONS AND EXCEPTIONS:

This coverage is extended to the original purchaser only. Prior warranty registration is not required but documented proof of purchase i.e. a copy of original sales invoice or receipt showing the date and location of the purchase as well as the purchase price paid, must be provided at the time of claim.

Warranty does not include failures, breakage or defects deemed after inspection by General® or General® International to have been directly or indirectly caused by or resulting from; improper use, or lack of or improper maintenance, misuse or abuse, negligence, accidents, damage in handling or transport, or normal wear and tear of any generally considered consumable parts or components.

Repairs made without the written consent of General® International will void all warranty.

TABLE OF CONTENTS

Rules for safe operation	5
Additional Safety Instructions for Scroll Saw	6
Electrical requirements	7
Grounding instructions	7
Extension cords	7
Identification of main parts and components	8
Unpacking & Handling	9
List of contents	9
Handling	9
Installation & Assembly	9
Attaching the power cord	9
Install the saw on a stable surface	10
Attaching the leveling feet	10
Installing the optional stand	10
Mounting to a work surface	10
Dust collector outlet	11
Choosing & Installing a Saw Blade	11
Blade selection	11
Blade storage	11
Installing or changing blades	13
Operating Instructions	14
On/Off switch	14
On/Off switch padlock	14
Adjusting the blade speed	14
Adjusting the blower	14
Workpiece hold-down	14
Basic 90° straight or curved cuts	15
Fret cutting	15
Angle or bevel cutting	17
Maintenance, Adjustments & Servicing	17
Blade clamping thumbscrews/set screws	17
Blade tension lever lubrication	18
Blade tension lever replacement	18
Upper arm adjustment for fret work	18
Squaring the blade to the table	18
Maintenance	19
Recommended Optional Accessories	19
Parts list & diagrams	20-25

Rules for Safe Operation

To help ensure safe operation, please take a moment to learn the machine's applications and limitations, as well as potential hazards. General® International disclaims any real or implied warranty and hold itself harmless for any injury that may result from the improper use of its equipment.

1. Be sure to read, understand and follow all safety warnings and instructions in the supplied Operator's Manual.
2. Do not operate the saw when tired, distracted, or under the effects of drugs, alcohol or any medication that impairs reflexes or alertness. Stay alert! Give your work your undivided attention.
3. Keep the work area well lit, clean and free of debris. Cluttered areas and benches invite injuries.
4. Keep children and shop visitors at a safe distance while operating the saw; do not permit them to operate the scroll saw.
5. Childproof and tamper proof your shop and all machinery with locks, padlocks, master electrical switches and switch keys, or by removing starter keys to prevent unauthorized or unsupervised use.
6. Fine particulate dust is a carcinogen that can be hazardous to health. Work in well ventilated area and use a dust collector whenever possible.
7. Wear approved safety glasses, dust mask and non-skid footwear. Do not wear loose clothing, gloves, bracelets, necklaces or jewellery while operating the saw. Keep long hair contained by wearing protective hair covering.
8. Be sure all adjustment tools, wrenches or other clutter are removed from the machine and/or the table surface before operation. When not in use, tools should be locked-up in a dry place, out of children's reach and away from flammable substances.
9. Keep hands well away from saw blade and all moving parts. Use a brush, not hands, to clear away chips and sawdust.
10. Be sure that saw blade is properly installed, and in proper cutting direction, before operation. Always use a clean, properly sharpened blade. Dirty or dull blades are unsafe and can lead to accidents. Also, be sure the blade has gained full operating speed before beginning to cut.
11. Do not push or force stock into the blade. The saw will perform better and more safely when working at the rate for which it was designed. Do not use for purposes not intended.
12. Avoid working from awkward or off balance positions. Do not overreach while cutting; keep both feet on floor. Never lean over or reach behind the blade and never pull the workpiece through the cut from behind.
13. Never stand or lean on the saw. Serious injury could occur if the unit is tipped over or if the blade is unintentionally contacted.
14. Use of parts and accessories NOT recommended by General® International may result in equipment malfunction or risk of injury.
15. Never leave the machine unattended while running or with the power "ON". Don't leave tool until it comes to a complete stop.
16. Always turn off and disconnect from power source before servicing or changing accessories, blades, bits, and cutters, or before performing any maintenance or adjustments.
17. Reduce the risk of unintentional start-up. Make sure that switch is in the "OFF" position before plugging in the power cord. Do not use the saw if the power switch is defected. Have defective switches replaced by an authorized service center.
18. Make sure saw is properly grounded. If equipped with a 3-prong plug it should be used with a three-pole receptacle. Never remove the third prong. Avoid body contact with grounded surfaces (e.g. pipes, radiators, stoves, refrigerators).
19. Repairs to the saw should only be carried out by qualified people using original spare parts. A guard or other damaged part should be properly repaired or replaced by an authorized service center.
20. Inspect power cords and extension wires periodically. If damaged, have them repaired by an authorized service facility. Never yank cords and wires and keep away from heat, oil, and sharp edges.
21. This tool is for indoor use only. Do not expose to rain or use in wet or damp locations.



Additional Safety Instructions

Specific to this Scroll Saw



Because each shop situation is unique, no list of safety guidelines can ever be complete. The most important safety feature in any shop is the knowledge and good judgement of the user. Use common sense and always keep safety considerations, as they apply to your individual shop situation first and foremost in mind. If you have any doubts about the safety of an operation you are about to perform: STOP! Do not perform the operation until you have validated from qualified individuals if the operation is safe to perform and what is the safest method to perform it.

1. Material hold-down must be properly set and remain in position during use.
2. Never reach under the table when operating or make any adjustments while the scroll saw is running.
3. Secure the saw to the work bench with clamps or mounting hardware.
4. Where possible, use clamps or a vice to secure your workpiece. It is safer than using your hand.
5. Do not lift or carry the saw by the upper arm.
6. Make sure blade tension is properly adjusted.
7. Avoid awkward hand positions where a sudden slip could cause a hand to move into the saw blade. Do not place fingers or hands in the path of the saw blade.
8. When removing short workpieces, or cleaning up around the table, be sure that the switch is in the OFF position and that the blade has come to a complete stop.
9. Never turn the saw ON before making sure that the table is clear except for the workpiece and related feed or support devices for the operation planned.
10. Check for proper blade size and type.
11. Do not attempt to saw stock that does not have a flat surface unless a suitable support is used.
12. Turn off motor if the material resists being backed out of an incomplete cut. Use appropriate speed for applications.
13. CAUTION: Some wood contains preservatives such as copper chromium arsenate (CCA) which can be toxic. When cutting these materials, extra care should be taken to avoid inhalation and to minimize skin contact.
14. Always use a dust mask and safety glasses when sawing. Everyday eyeglasses only have impact resistant lenses, they are NOT safety glasses.
15. Keep guards in place and in working order.
16. Make sure your fingers do not contact the terminals of the power cord plug when plugging in or unplugging the saw.
17. Never overfeed or force work into the blade.
18. Check for alignment and binding of all moving parts, broken parts, mounting and any other conditions that may affect the saw's operation.
19. Keep handles dry and free from oil and grease.
20. MAINTAIN TOOLS WITH CARE. Keep tools sharp and clean for best and safest performance. Follow instructions for lubricating and changing accessories.
21. DIRECTION OF FEED. Feed work into a blade or cutter against the direction of rotation of the blade or cutter only.



TO AVOID ELECTRICAL SHOCK, ENSURE MACHINE IS PROPERLY GROUNDED. DO NOT OPERATE IN DAMP CONDITIONS. DISCONNECT FROM POWER SUPPLY BEFORE SERVICING. REPLACE FUSE WITH THE SAME TYPE AND RATING ONLY - 3 AMP.

BE SURE TO READ AND UNDERSTAND OWNER'S MANUAL BEFORE OPERATING.

ELECTRICAL REQUIREMENTS



BEFORE CONNECTING THE MACHINE TO THE POWER SOURCE, VERIFY THAT THE VOLTAGE OF YOUR POWER SUPPLY CORRESPONDS WITH THE VOLTAGE SPECIFIED ON THE MOTOR I.D. NAMEPLATE. A POWER SOURCE WITH GREATER VOLTAGE THAN NEEDED CAN RESULT IN SERIOUS INJURY TO THE USER AS WELL AS DAMAGE TO THE MACHINE. IF IN DOUBT, CONTACT A QUALIFIED ELECTRICIAN BEFORE CONNECTING TO THE POWER SOURCE.

THIS TOOL IS FOR INDOOR USE ONLY. DO NOT EXPOSE TO RAIN OR USE IN WET OR DAMP LOCATIONS.

GROUNDING INSTRUCTIONS

In the event of an electrical malfunction or short circuit, grounding reduces the risk of electric shock. The motor of this machine is wired for 120V single phase operation and is equipped with a 3-conductor cord and a 3-prong grounded plug to fit a grounded type receptacle, **A**.

Do not remove the 3rd prong (grounding pin) to make it fit into an old 2-hole wall socket. If an adaptor plug is used, **B**, it must be attached to the metal screw of the receptacle.

Note: The use of an adaptor plug is illegal in some areas, including Canada. Check your local codes.

Grounded, cord-connected tools intended for use on a supply circuit having a nominal rating less than 150 volts: This tool is intended for use on a circuit that has an outlet that looks like the one illustrated in **A**. The tool has a grounding plug that looks like the plug illustrated in **A**. A temporary adapter, which looks like the adapter illustrated in **B** and **C**, may be used to connect this plug to a 2 pole receptacle as shown in **B** if a properly grounded outlet is not available. The temporary adapter should be used only until a properly grounded outlet can be installed by a qualified electrician. This adapter is not permitted in Canada. The green-colored rigid ear, lug and the like, extending from the adapter, must be connected to a permanent ground such as a properly grounded outlet box.

This tool is equipped with an electric cord having an equipment-grounding conductor and a grounding plug. The plug must be plugged into a matching outlet that is properly installed and grounded in accordance with all local codes and ordinances.

Improper connection of the equipment-grounding conductor can result in a risk of electric shock. The conductor with insulation having an outer surface that is green with or without yellow stripes is the equipment-grounding conductor. If repair or replacement of the electric cord or plug is necessary, do not connect the equipment-grounding conductor to a live terminal.

DO NOT MODIFY THE PLUG PROVIDED.

If it will not fit your receptacle, have the proper receptacle installed by a qualified electrician.

CHECK with a qualified electrician or service person if you do not completely understand these grounding instructions, or if you are not sure the tool is properly grounded.

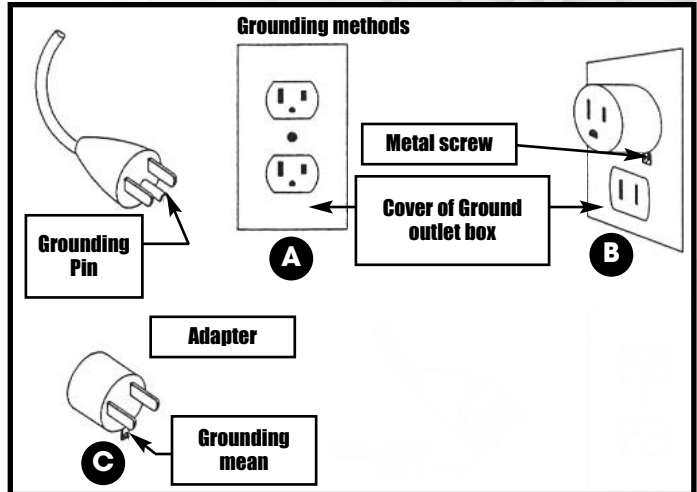

EXTENSION CORDS

USE ONLY 3-WIRE EXTENSION CORDS THAT HAVE 3-PRONG GROUNDING PLUGS AND 3-POLE RECEPTACLES THAT ACCEPT THE TOOLS' PLUG. REPAIR OR REPLACE A DAMAGED OR WORN POWER CORD OR PLUG IMMEDIATELY

If you find it necessary to use an extension cord with your machine make sure the cord rating is suitable for the amperage listed on the motor I.D. plate. An undersized cord will cause a drop in line voltage resulting in loss of power and overheating. The accompanying chart shows the correct size extension cord to be used based on cord length and motor I.D. plate amp rating. If in doubt, use the next heavier gauge. The smaller the number the heavier the gauge.

AMPERES (AMPS)	EXTENSION CORD LENGTH					
	25 Feet	50 Feet	75 Feet	100 Feet	150 Feet	200 Feet
< 5	16	16	16	14	12	12
5 à 8	16	16	14	12	10	NR
8 à 12	14	14	12	10	NR	NR
12 à 15	12	12	10	10	NR	NR
15 à 20	10	10	10	NR	NR	NR
21 à 30	10	NR	NR	NR	NR	NR

*Based on limiting the line voltage drop to 5V at 150% of the rated amperes. **NR = Not Recommended**



SCROLL SAW

EX-16, EX-21 or EX-30

IDENTIFICATION OF MAIN PARTS AND COMPONENTS

(EX-21- shown)

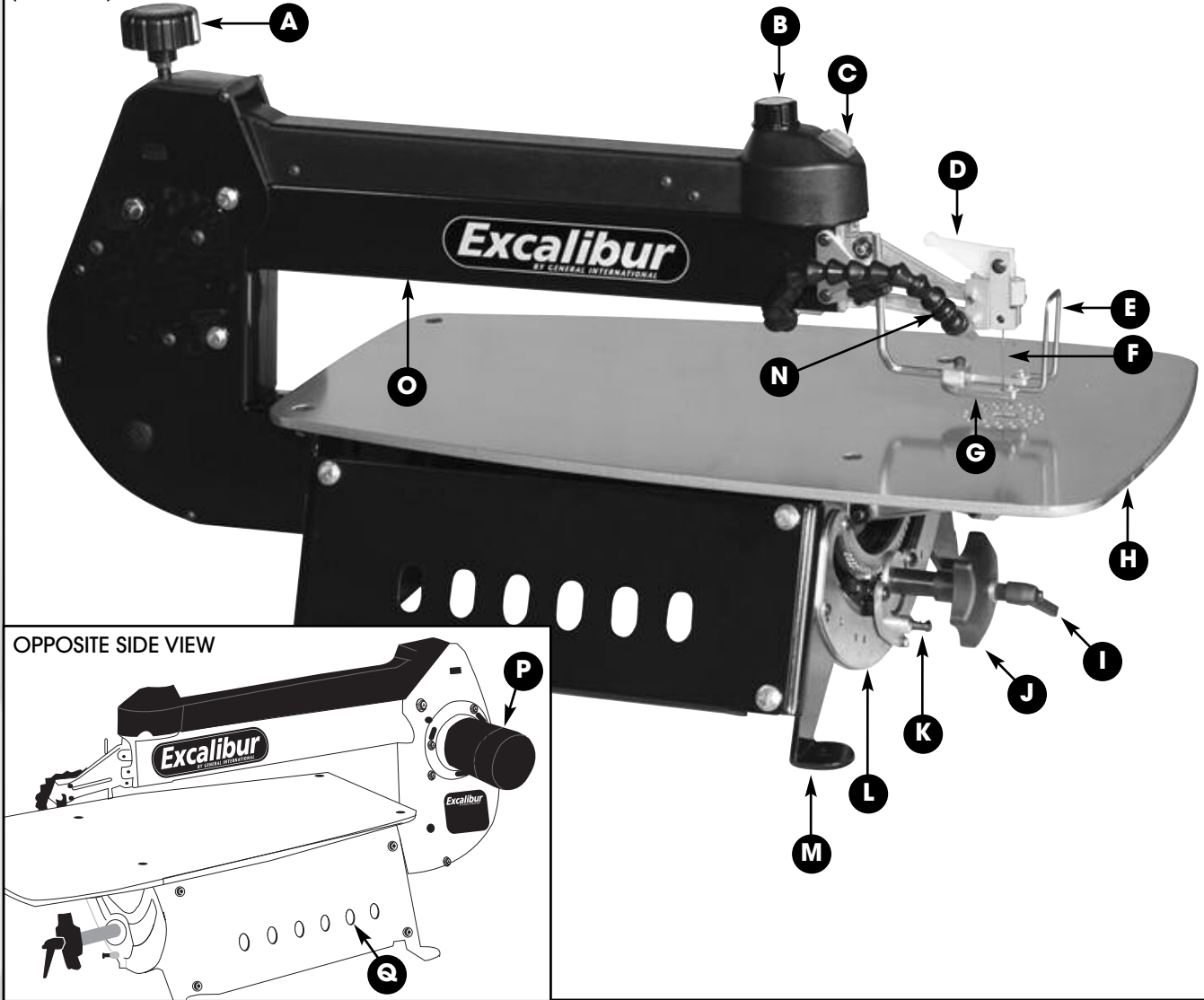

- | | |
|--|----------------------------------|
| A- UPPER ARM ADJUSTER | J- TILT HANDLE |
| B- VARIABLE BLADE SPEED CONTROL KNOB | K- ANGLE INDICATOR |
| C- ON/OFF SWITCH (WITH SAFETY DEVICE) | L- ANGLE ADJUSTMENT SCALE |
| D- BLADE TENSION LEVER | M- MOUNTING HOLES (4) |
| E- BLADE GUARD | N- BLOWER |
| F- BLADE | O- UPPER ARM |
| G- WORKPIECE HOLD DOWN | P- MOTOR |
| H- TABLE | Q- BLADE HOLDER SOCKETS |
| I- BLADE TILT LOCKING LEVER | <i>(EX-21 & EX-30 ONLY)</i> |

UNPACKING & HANDLING

Carefully unpack and remove the scroll saw and its components from the box and check for damaged or missing items as per the list of contents below.

NOTE: Please report any damaged or missing items to your General International distributor immediately.

LIST OF CONTENTS	QTY
A - SCROLL SAW	1
B - POWER CORD	1
C - HEX NUT	8
D - LEVELING FOOT	4
E - 3 MM ALLEN KEY	1
F - BLADE	1

NOTE: Unscrew the 4 shipping bolts and remove the saw from the protective plywood shipping base.

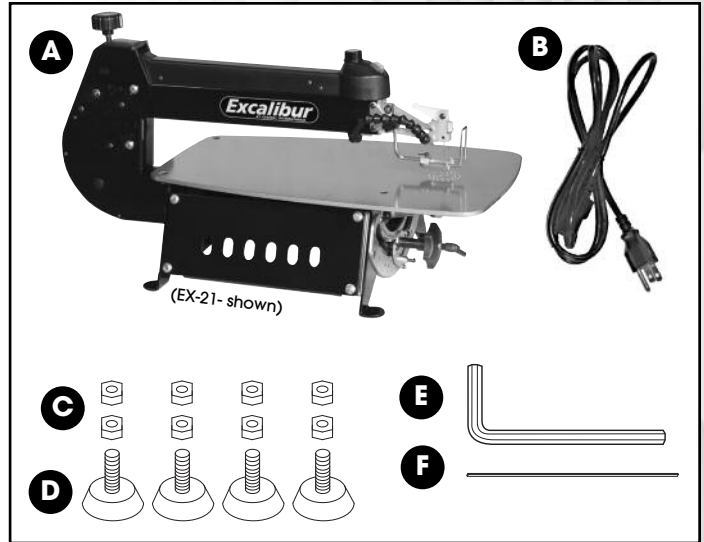

HANDLING

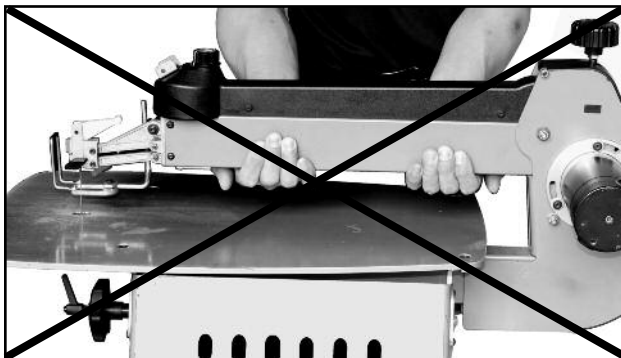

Never lift the saw by the upper arm assembly as this will result in damage to the drivetrain.



Rather lift the saw by the front of the table and by the motor.

INSTALLATION & ASSEMBLY

For your convenience this scroll saw is shipped from the factory partially assembled and requires only minimal assembly and set-up before being put into service.

ATTACHING THE POWER CORD

Plug the female end of the power cord into the socket at the rear of the saw as shown.



BEFORE STARTING THE ASSEMBLY, MAKE SURE THAT THE SWITCH IS IN THE "OFF" POSITION AND THAT THE POWER CORD IS UNPLUGGED.

DO NOT PLUG IN OR TURN ON THE SCROLL SAW UNTIL YOU HAVE COMPLETED THE ASSEMBLY AND INSTALLATION STEPS DESCRIBED IN THIS SECTION OF THE MANUAL.

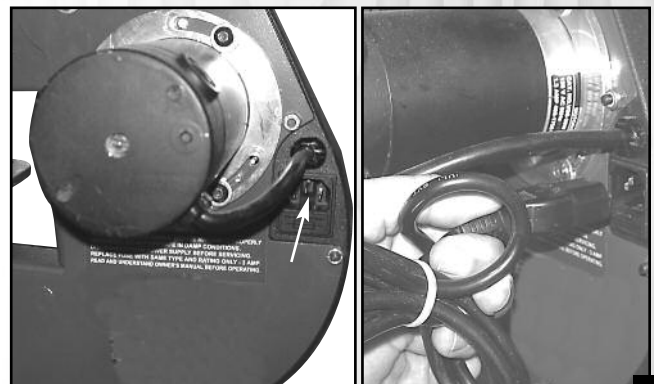

INSTALL THE SAW ON A STABLE SURFACE

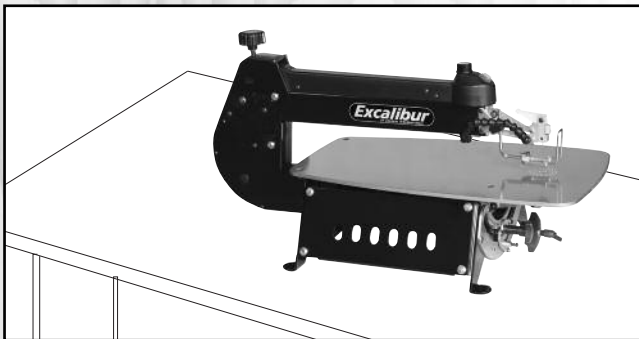

The unit should be installed on a flat, sturdy and stable surface able to support the weight of the machine and the workpiece with ease.

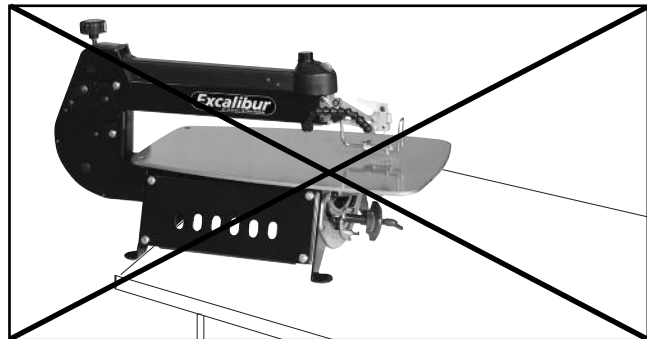

Never install the machine over the edge of a table or workbench.

ATTACHING THE LEVELING FEET

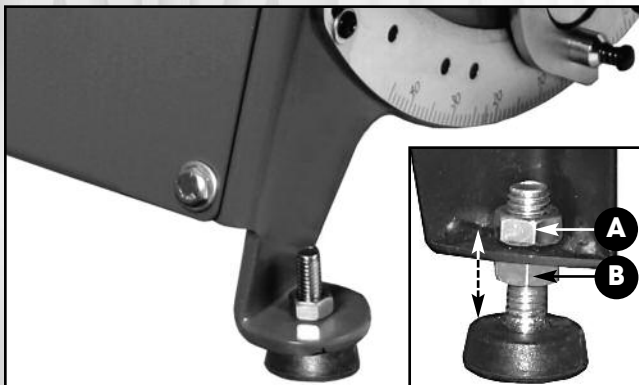

Install the leveling feet as shown. Loosen the upper **A** and lower **B** nuts as needed to adjust the height of the foot.

INSTALLING THE OPTIONAL STAND

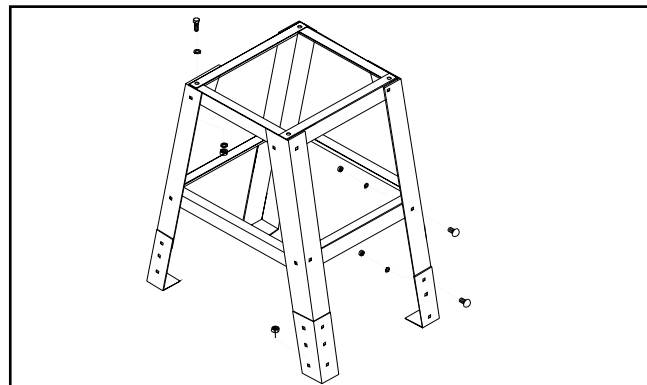

If you prefer, an optional stand (item EX-21BS for EX-16 & EX-21 or item EX-30BS for EX-30) is available from your local General International dealer. The stand is equipped with mounting holes allowing the saw, after removing the leveling feet, to be bolted directly to the stand.



FOR YOUR SAFETY IT IS ESSENTIAL THAT THE MACHINE DOES NOT ROCK OR TIP DURING OPERATION. UPON START-UP OR DURING OPERATION, IF YOU NOTICE ANY ROCKING, TIPPING OR CHATTERING OF THE BASE TURN THE MACHINE OFF IMMEDIATELY AND READJUST THE LEVELING FEET AS NEEDED TO STABILIZE THE SCROLL SAW ON THE BENCH OR WORK SURFACE

MOUNTING TO A WORK SURFACE

If a permanent shop placement is practical, consider removing the leveling feet on the base and drilling matching through holes in the mounting surface of your workbench or stand to bolt the saw in place (hardware not included) on your workbench.

If a permanent installation is not practical, clamps can also be used to secure the saw to a bench or work table.

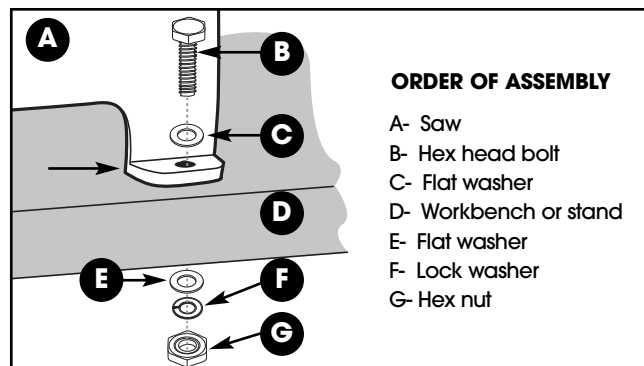

DUST COLLECTOR OUTLET

The dust collector outlet on this saw allows for hook-up to a user supplied shop vacuum or dust collector.

Note 1: The dust collector outlet reduces clearance under the table, and limits the left tilt capacity of the saw to 30° (for model EX-16, and to 38° for models EX-21 and EX-30).

Note 2: If desired, the dust collector outlet can be removed to recover a maximum left tilt capacity of 45°.

Proceed as follows:

With the saw turned off and unplugged, loosen and remove the 4 screws and washers **A** that attaches the dust collector outlet to the underside of the table

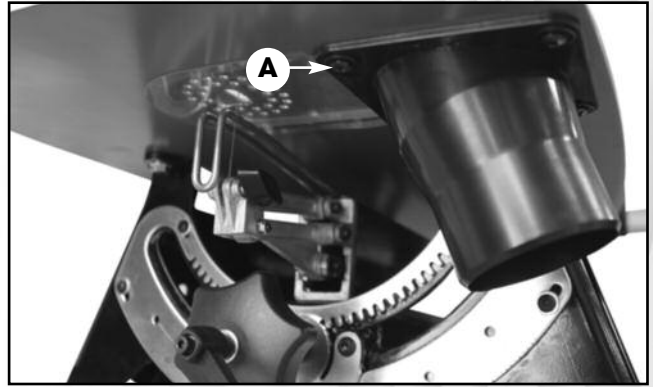

ALWAYS TURN OFF AND UNPLUG THE MACHINE BEFORE REMOVING OR INSTALLING ANY COMPONENT.

CHOOSING & INSTALLING A SAW BLADE

BLADE SELECTION

Blade selection is dependent on the type and thickness of the material being cut, but is also a matter of experience and personal preference. There are numerous types of blades available on the market specifically suited for various cutting applications such as metal-cutting and spiral blades which cut in all directions.

Try test-cutting with a sample of each to determine which blade works best for you with different materials. Replacement and specialty blades can be purchased from a variety of sources. Ask your local tool or scroll saw dealer for suggestions for **unpinned 5" scroll saw blades** based on what is available in your area.

Some general guidelines to consider when choosing blades:

- Wide, thick blades with coarse teeth are suited to cutting straight lines and sweeping curves, but will not turn tight corners. They will cut aggressively and leave a fairly smooth finish, but may leave burn marks if the work piece is turned too tightly.
- Narrower, thinner blades with finer teeth will cut more slowly, but will turn much tighter corners for cutting very intricate work. They will impart a very smooth, burnished finish that requires no sanding.
- Consider material thickness when selecting blades. Ensure that a minimum of two or three teeth are in contact with the workpiece at all times. For example, when cutting 1/8" thick material, use a blade with a minimum of 16-20 teeth per inch.

Blade Storage (for models EX21 & EX-30 only):

There are sockets (mounting holes) on either side of the base of the saw to hold blade storage "test tubes" (tubes not supplied). Most blade retailers sell blades either already in the tubes or will be able to sell spare tubes separately. Storing your spare blades in tubes, by size, right on the base of the machine can be a great way to organize your spare blades so that they are handy and available when needed.

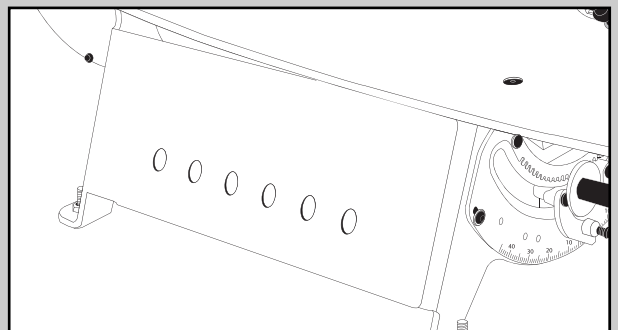

SKIP TOOTH



Regular evenly spaced tooth pattern. Considered the most common of scroll saw blades, they are available in the widest range of sizes and provide a good combination of fast cutting action with good chip clearance and a relatively smooth finish.

BLADE	WIDTH	THICKNESS	TEETH/INCH	
#2/0	.022	.010	28	For extremely intricate sawing. Very tight cuts in 1/16" - 1/4" wood veneer, plastic, hard rubber, pearl, etc.
#0	.024	.011	25	
#2	.029	.012	20	For tight radius work with thin materials, 3/32" - 1/2" wood veneer, wood, bone, fiber, plastic, etc.
#4	.035	.015	15	
#5	.038	.016	12.5	For close radius work in materials 1/8" or thicker. Good for sawing hard and soft woods, bone, horn, plastic, etc.
#6	.041	.016	12.5	
#7	.045	.017	11.5	Popular sizes for cutting hard and soft woods, 3/16" up to 2". Also cuts plastic, paper, felt, bone, etc.
#9	.053	.018	11.5	
#11	.059	.019	9.5	
#12	.062	.024	9.5	

REVERSE TOOTH



Reverse teeth at the bottom of the blades prevent splintering to the underside of the workpiece.

BLADE	WIDTH	THICKNESS	TEETH/INCH	Same applications as Skip Tooth blades.
#2/OR	.026	.011	28/20	
#2R	.029	.012	20/13	
#5R	.038	.016	12.5/9	
#7R	.049	.018	11.5/8	
#9R	.054	.019	11.5/8	
#12R	.062	.062	9.5/6	

DOUBLE TOOTH



Fast, clean cutting and very efficient chip clearance.

BLADE	WIDTH	THICKNESS	TEETH/INCH	Same applications as Skip Tooth blades.
#1D	.026	.013	30	
#3D	.032	.014	23	
#5D	.038	.016	16	
#7D	.044	.018	13	
#9D	.053	.018	11	
#12D	.061	.022	10	

INSTALLING OR CHANGING BLADES



ALWAYS TURN OFF AND UNPLUG THE MACHINE BEFORE REMOVING, HANDLING OR CHANGING BLADES.

1. Remove an installed, worn or broken blade by flipping the blade tension lever forward (position 1), then loosening the thumbscrews **A** and **C** on the upper and lower blade mounts **B** and **D**.
2. Remove the blade.
3. Verify that the upper arm is more or less parallel (within 1/8") to the saw table. If necessary, use the upper arm adjuster **K** (below) to raise or lower the arm as needed.
4. With the blade teeth facing forward and downward slip the bottom of the blade down through the hole in the table. Then slip the upper end of the blade into the slot in the upper blade mount and position the top of the blade above the set screw **E** but no higher than the top of the shoulder **F** on the blade mount. Then tighten the thumbscrew only enough to secure the blade in the mount and prevent it from slipping out.
5. The bottom portion of the blade may protrude beyond the bottom of the lower blade mount, this is normal and will not affect performance. Only the upper portion of the blade requires proper positioning in the upper blade mount.

Note: Overtightening the blade clamp thumbscrews can cause premature wear to the blades gripping surface and result in blade slippage or cause premature wear of the threads in the blade clamp housing.

To avoid kinking or damaging the blade in the holder, **G**, when making adjustments make sure the set screw **H** (opposite the thumbscrew **I**) is threaded into the holder to protrude slightly beyond the blade slot **J**.

6. Push the blade tension lever back (position 2) to apply tension on the blade.

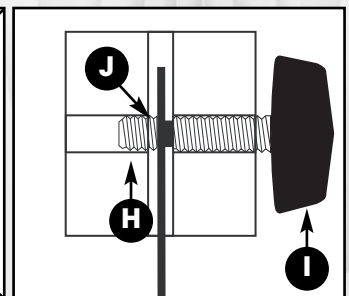
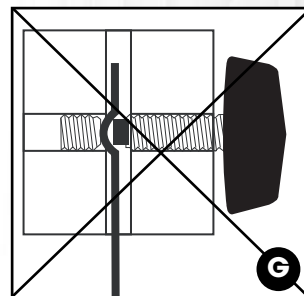
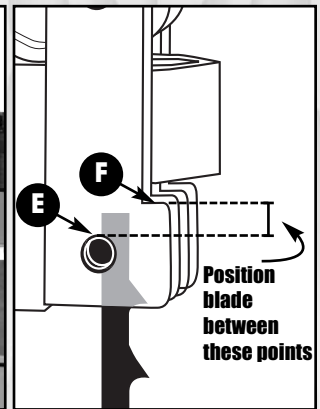
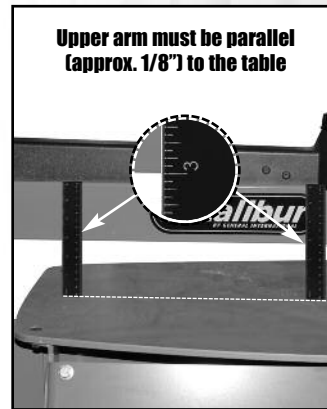
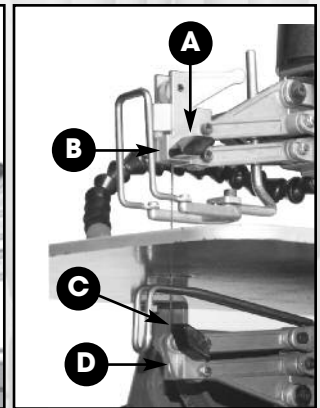
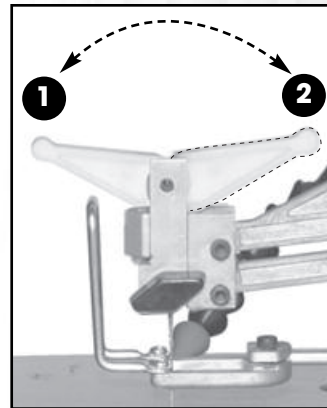

Helpful Hints on blade tension

Determining correct blade tension is somewhat subjective. It is learned through experience and is somewhat dependant on personal preference. A properly tensioned blade will last longer and be much less likely to break prematurely. If the blade tension is too loose, you will notice that the blade will have a tendency to drift or slip off-line when cutting and you may also experience excessive vibration or unusual noise. A blade that is too tight will break prematurely.

Assuming the blade has been properly installed in the blade mounts, when the blade tension lever is pushed fully back towards the rear of the saw, the blade should be properly tensioned.

Test the blade tension by lightly plucking on the blade, like you would a guitar string, with your finger. If the blade is tight and tensioned correctly you will get a clear and even note. If so, you are ready to proceed to operating and cutting with the saw. If not, for some cases after double checking that the blade is properly installed in the blade mounts, further blade tension fine tuning can be made by adjusting the rear knob to raise the upper arm slightly. **Note:** this is not the main function of the adjustment knob (see following paragraph) and using this knob as the primary blade tensioner will cause premature wear and damage to the machine.

This saw has an adjustment knob **K** in the rear that can raise the blade mount up to 1" (25 mm). This allows you to fine tune blade tension when needed, as well as to reposition the saw blade at a point where you can use a different part of the blade in the cutting area. This also allows you to use a piece of band saw blade, cut to a length of 5"- 6" (127-150 mm) in your saw, and gives you up to 3 inch cutting capacity when needed.

Note: Do not over tension the knob as this can cause premature wear and damage to the machine.



OPERATING INSTRUCTIONS

ON / OFF SWITCH

The saw is equipped with a simple dust protected rocker style on/off switch **A**, featuring a protection device **B** to prevent unwanted or unintentional start-up

ON / OFF SWITCH PADLOCK

To avoid accidental starting by young children or others not qualified to use the tool, the use of a padlock **C** is required.

1. Open the padlock.
2. Insert through holes in the on/off switch.
3. Close the padlock.
4. Place the key in a safe place out of the reach of children.

ADJUSTING THE BLADE SPEED

The Scroll Saw is equipped with a variable speed control which allows you to select or fine-tune to the exact blade speed required (from 400-1400 strokes per minute for the EX-16 model & from 400-1550 strokes per minute for EX-21 & EX-30 models) for best results based on the type and thickness of material and type of blade being used.

The blade speed control knob **D** is located on the top of the machine.

- To increase blade speed, turn the control knob clockwise.
- To decrease blade speed turn the control knob counterclockwise.

Blade speed selection is subjective and is dependant on a variety of factors: type and thickness of material being cut, type of blade being used, feed rate, required finish quality as well as experience, personal preference and comfort level of the user. There are no hard and fast rules. Be patient - practice and experience will be your best teacher.

Here are some general guidelines to consider when selecting/adjusting blade speed:

- For best results and smoothest most efficient cutting, always select the highest speed that you are comfortable using based on your experience and skill level.
- Generally speaking, harder or denser workpiece material requires slower blade speeds.
- Slower speeds also work better with very thin blades, or when cutting most metals, as well as for brittle or delicate material such as fine veneers.
- Some wood species will have a tendency to burn quicker at higher blade speeds. To avoid additional sanding later, reduce blade speed and feed speed at the first signs of burn marks on the workpiece.

ADJUSTING THE BLOWER

The saw is equipped with a built-in blower to help clear cutting dust from the workpiece surface in front of the blade and on any reference lines. Adjust the blower tube **A** as needed to point the nozzle at the blade to set it at a comfortable distance so as not to obstruct your hand movement as you work.

WORKPIECE HOLD-DOWN

The workpiece hold-down **B** can be adjusted to assist in preventing the blade from lifting the workpiece up from the table during the cut. Loosen the thumbscrew **C** to set the height to your convenience based on the thickness of the workpiece. Before cutting, test to make sure that the hold-down is not adjusted too tightly to the workpiece or that it obstructs the movement of the workpiece.

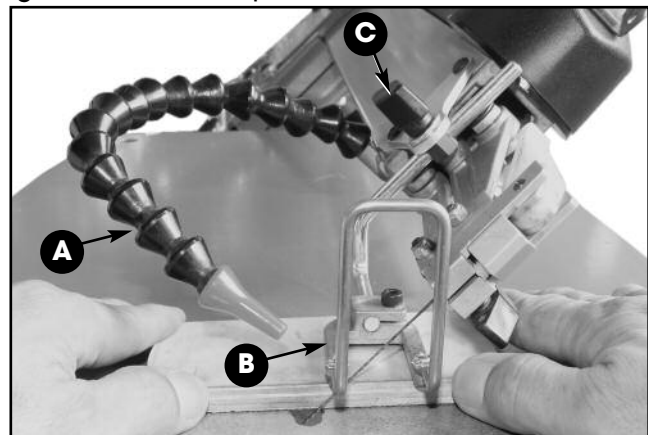
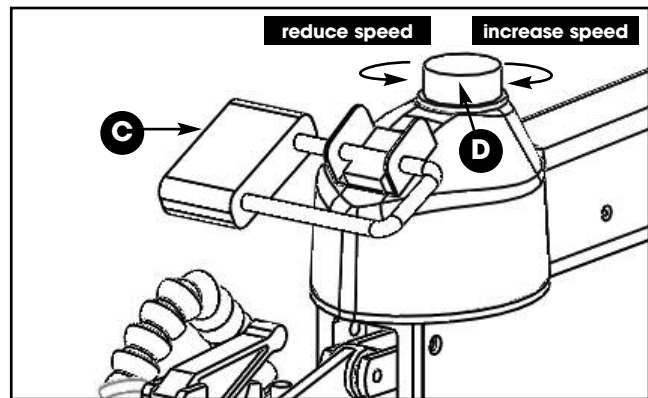
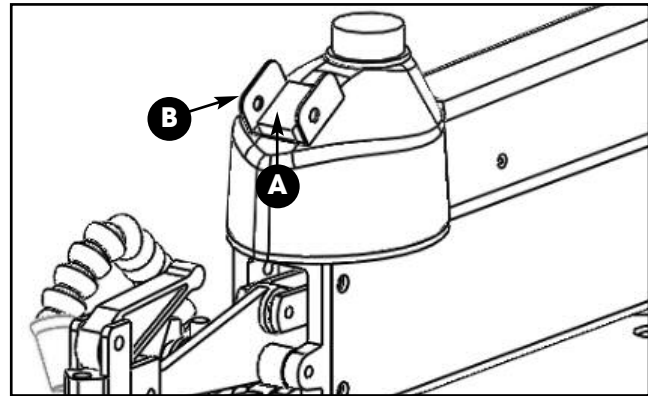

BASIC 90° STRAIGHT OR CURVED CUTS

All cuts made with the blade at 90° to the table follow the same basic principals. Start by marking or transferring your pattern or reference lines onto your workpiece.

Maximum workpiece size from blade to rear of saw

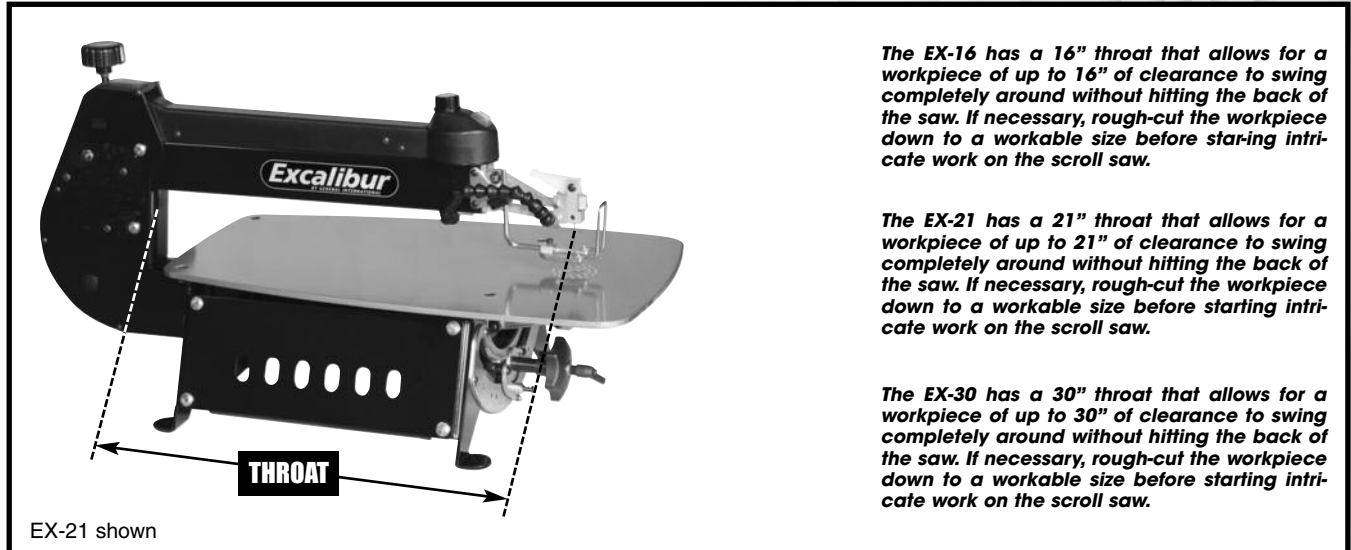

EX-21 shown

The EX-16 has a 16" throat that allows for a workpiece of up to 16" of clearance to swing completely around without hitting the back of the saw. If necessary, rough-cut the workpiece down to a workable size before starting intricate work on the scroll saw.

The EX-21 has a 21" throat that allows for a workpiece of up to 21" of clearance to swing completely around without hitting the back of the saw. If necessary, rough-cut the workpiece down to a workable size before starting intricate work on the scroll saw.

The EX-30 has a 30" throat that allows for a workpiece of up to 30" of clearance to swing completely around without hitting the back of the saw. If necessary, rough-cut the workpiece down to a workable size before starting intricate work on the scroll saw.

1. With the saw turned off and unplugged, install the appropriate blade for the type of material to be cut and the type of cut to be made (Refer to the section "Choosing and Installing a Saw Blade" on page 11).
2. Adjust the workpiece hold-down and the blower nozzle to your liking.
3. Turn on the saw and set the speed controller to the desired blade speed.
4. With your fingers holding the piece firm to the table, and using your thumbs for directional control, feed the workpiece into the blade using steady, even pressure.
5. Make sure that the blade is cutting on the waste side of your reference line and adjust feed direction slightly as needed to compensate for blade drift.

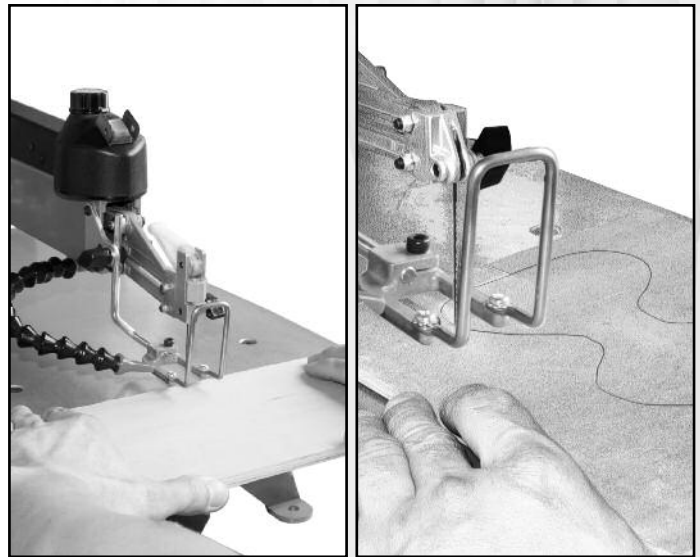

Cutting Tips: To stay in control on tight curve cuts, slow down your feed rate as needed to allow the blade teeth time to make the cut. Avoid coming to a complete stop whenever possible as this can leave burn marks on the workpiece and also makes it more difficult to get the piece re-started and moving through the cut again. Avoid forcing through a curve cut as this can cause the blade to twist and cut off-track or may even cause the blade to break.

FRET CUTTING

Fret or inside cutting is an operation that can only be performed on a scroll saw. Fret cutting involves drilling a small pilot hole through the interior of your pattern on the workpiece, then disconnecting one end of the blade which is fit through the pilot hole and re-connected; essentially using the pilot hole as the starting point to cut out the piece from within. A typical example of fret cutting would be removing the center portion of lettering **A**.

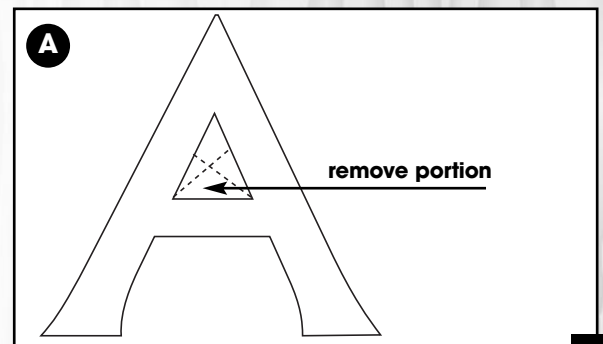

The saw is a great tool for fret cutting because unlike most scroll saws it allows you to raise the upper arm with the blade attached **B**, line up the guide hole in your workpiece with the hole in the table and then lower the arm while guiding the blade through the hole from above (see step by step instructions below). This can be a very useful time saving feature, particularly for intricate or complex fret designs that can involve dozens or even hundreds of holes.

1. With the saw turned off and unplugged, install the appropriate blade for the type of material to be cut and the type of cut to be made (Refer to the section "Choosing and Installing a Saw Blade" on page 11 of this manual).
2. With your pattern or design transferred onto the workpiece, drill a guide hole in the inside waste portion of the workpiece **C**. Make sure that the hole is large enough for the blade to fit through.

Helpful hints on drilling guide holes: If multiple fret cuts are required on the same workpiece, drill all of your required guide holes before taking the workpiece to the scroll saw. This will keep you from going back and forth from the saw to the drill press.

To prolong blade life by limiting unnecessary cutting, drill your guide holes as close as possible to your reference lines **D.**

3. Release tension on the blade by flipping the blade tension lever forward.
 4. Loosen the thumbscrew on the lower blade mount, located under the table, to release the blade from the mount.
 5. Raise the upper arm assembly which will lift the blade up through the hole and above the table.
 6. Position the workpiece on the table so that the guide hole lines up with the hole in the table.
 7. Lower the arm assembly with one hand while guiding the blade through the hole in the workpiece and table.
 8. Re-install the bottom end of the blade in the lower blade mount and tighten the thumbscrew, only enough to secure the blade in the lower blade clamp and prevent it from slipping.
- Note: Overtightening the blade clamp thumbscrews can cause premature wear to the blades gripping surface and result in blade slippage or cause premature wear of the threads in the blade clamp housing. (added this since Norm's copy)**
9. Flip back the blade tension lever to re-tension the blade and test the blade tension as described in "Installing or Changing Blades" section of this manual.
 10. To begin cutting follow the same steps as described in "Basic 90° straight or curved cuts" section on page 14 of this manual.

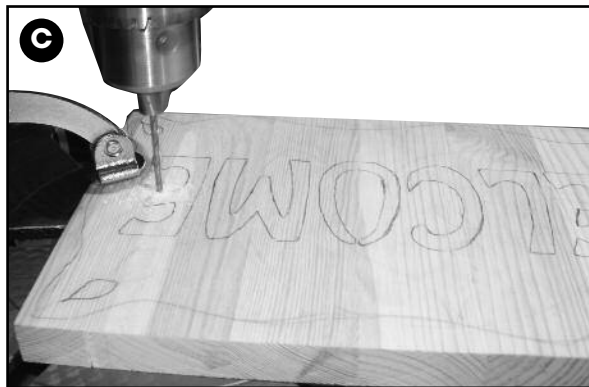

TO REDUCE THE RISK OF INJURY, ALWAYS TURN OFF THE SAW AND WAIT FOR THE BLADE TO COME TO A COMPLETE STOP BEFORE REACHING IN TO REMOVE WASTE MATERIAL FROM A FRET CUT.

ANGLE OR BEVEL CUTTING

One of the unique features of the Scroll Saw is the ability to tilt the head of the saw in order to make angle or bevel cuts.

The table and the workpiece always stay horizontal (parallel to the floor) while the blade tilts, keeping your hands in the same comfortable cutting position as they would normally be for regular right angle cuts.

Because you are not fighting gravity or working with your hands or wrists bent in awkward positions, it can be a huge advantage and makes it easier and safer to make accurate bevel cuts.

The blade tilt controls are located under the table at the front saw. To tilt the blade for bevel cutting:

1. Release the locking lever **A** by turning counter-clockwise.
2. Turn the tilting handle **B** left or right to set the blade to the desired angle.

Note: Push in and hold the spring loaded indexing pin **C** to locate the following common angles: 90°, 45°, 30° & 22.5° both left and right.

When tilting the blade to the left at extreme angles, it may be necessary to remove and reverse the lower blade mount thumbscrew assembly in order to maximize clearance under the table. (D shows the lower blade mount in default position and E shows it reversed).

3. Tighten the locking lever **A** to secure the blade at the desired angle.
4. To begin cutting, follow the same steps as described in "Basic 90° straight or curved cuts" section on page 14 of this manual. Letter **F** shows the scroll saw in position for bevel cutting.

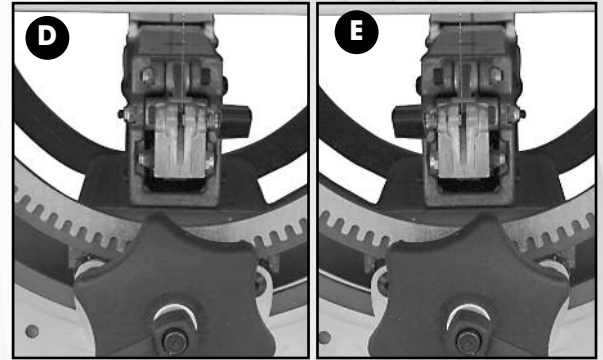
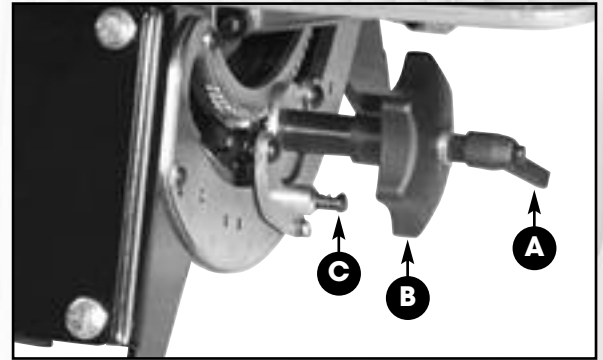

MAINTENANCE, ADJUSTMENTS AND SERVICING

BLADE CLAMPING THUMBSCREWS - SET SCREWS

Over time with normal use and wear, especially when doing a lot of internal cutting, where one end of the blade is frequently disconnected then reconnected to fit into a hole, the contact end of the thumbscrews **A** will wear and can become smooth to the point where it will no longer clamp the blade properly.

To avoid potentially costly downtime, consider keeping a spare set of replacement thumbscrews and set screws on hand for use if needed.

Note: If you begin to experience frequent blade slippage it may be a sign that it is time to replace the blade clamp thumbscrew **B** and/or the set screws opposite the thumbscrews **C**.

Note: Overtightening to compensate for blade slippage may damage, or in extreme cases strip, the threads in the blade clamping block.

Note: Before replacing either, always double check visually to make sure that the blade is being held between the set screw and the thumbscrew as shown in **D** and is not being bent or kinked into the opposite side of the blade clamping block because of a set screw that is adjusted too far back in the holder as shown in **E**.

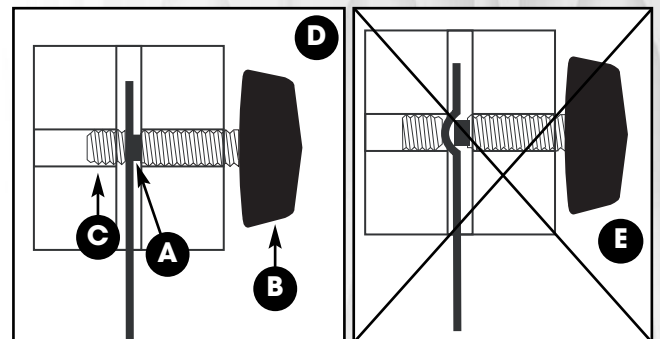

BLADE TENSION LEVER LUBRICATION

A regular application of white grease (or petroleum jelly) to the friction point (bottom) of the tension lever is recommended. This will allow for smoother operation as well as prolong the life of the tension lever. Apply a small dab of grease after every 10-15 hours of use or as needed depending on the frequency of use of the saw.



BLADE TENSION LEVER REPLACEMENT

Over time, with normal wear, the blade tension lever will need to be replaced.

1. Flip the lever forward as shown to release tension from the blade and remove the blade completely.
2. Loosen the barrel bolt using two phillips screwdrivers, and remove the binding screw and worn blade tension lever.
3. Install a new tension lever using the barrel bolt and binding screw.

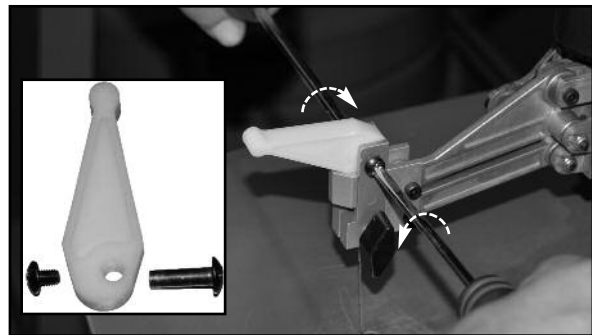

UPPER ARM ADJUSTMENT FOR FRET WORK

Over time and with normal wear the upper arm adjustment screw **A** may require slight adjustment in order to hold the arm in the raised position when the arm is lifted by the operator. To reset the adjustment screw:

1. Remove the blade and with the upper arm down set the arm more or less parallel to the saw table.
2. Loosen the lock nut **B**.
3. Turn the adjuster screw clockwise 1/4 turn at a time **B**, until there is just enough resistance to hold the arm in the raised position.
4. Re-tighten the lock nut and check again to make sure the upper arm will now stay up when lifted. If not repeat these steps, using slight 1/4 turn adjustments on the screw.

Note: Do not over tighten the adjustment screw! Over tightening the adjustment screw will apply too much tension and prevent the free movement of the arm during operations causing damage to your saw.

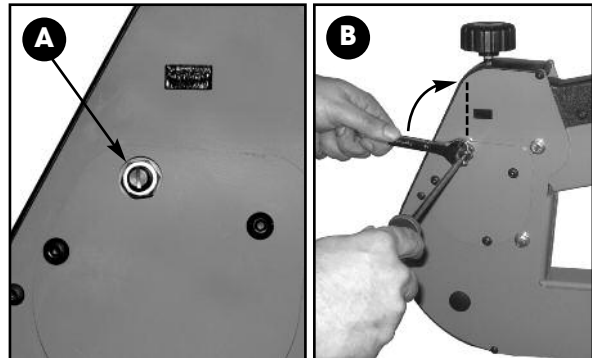

SQUARING THE BLADE TO THE TABLE

Depending on frequency of use and how much the tilting mechanism is used, normal wear will over time cause the blade to come slightly out of alignment with the table. Periodically check the blade for square with the table. When needed, adjust as described in the following steps to re-align the blade square to the table.

1. Turn off and unplug the saw.
2. Using the blade tilt controls at the front of the saw, set the blade angle to read 0 - which is 90° vertical to the table.
3. Set a machinists square on the table and against the blade to verify the blade angle, **C**.
4. If the blade angle requires adjustment loosen the 4 bolts in the front trunnion **D** as well as the 4 bolts on the rear trunnions **E**.
5. By hand, move the entire head to bring the blade square to the table.
6. With the blade square to the table hold the head in position and re-tighten the bolts on the front and rear trunnions.

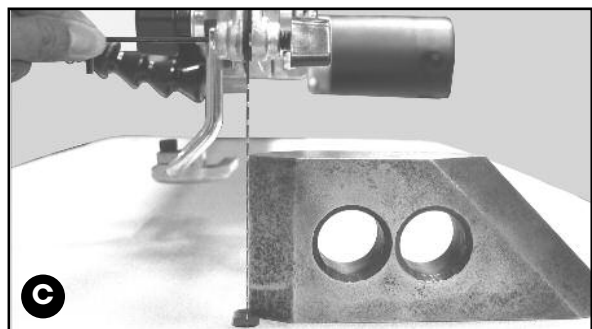

MAINTENANCE

- Always release tension on the blade when the saw is not in use.
- Clean the saw regularly with a soft bristle brush or by vacuuming to keep cutting dust from accumulating.
- An occasional application of a light dab of grease on the front and rear trunnions **F** will keep the tilting mechanism working smoothly. If you find the tilting mechanism becoming more difficult to operate, thoroughly wipe off any built-up cutting dust on the trunnions and re-apply a little grease.
- The bearings in the drive mechanism are sealed and permanently lubricated and do not need to be oiled or greased..

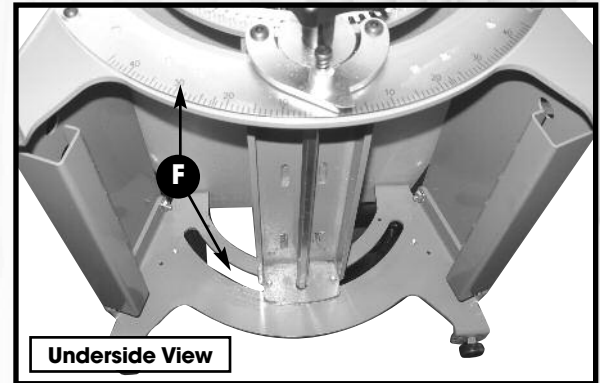

RECOMMENDED OPTIONAL ACCESSORIES

We offer some optional accessories available from your local General International dealer for increased convenience, productivity, accuracy and safety when using your scroll saw.

For more information about our products, please visit our website at www.general.ca



FOOT SWITCH: #EX-01

Enjoy hands-free on/off control of your scroll saw with this simple design, easy to use momentary style foot switch. Features

a 6 1/2 Ft. 16 gauge grounded power cord with a standard 110V 3-prong plug.

Constant "off" mode design: press and hold down switch to turn the saw "on" and simply lift foot from switch to turn the saw "off".



STAND: #EX-21BS / EX-30BS

Heavy duty adjustable height, flared steel stand, designed specifically to fit your EX-16, EX-21 (EX-21BS) or EX-30 (EX-30BS) scroll saw. Wide stance design with sturdy cross-bracing for stable vibration-free operation.

Notes

A

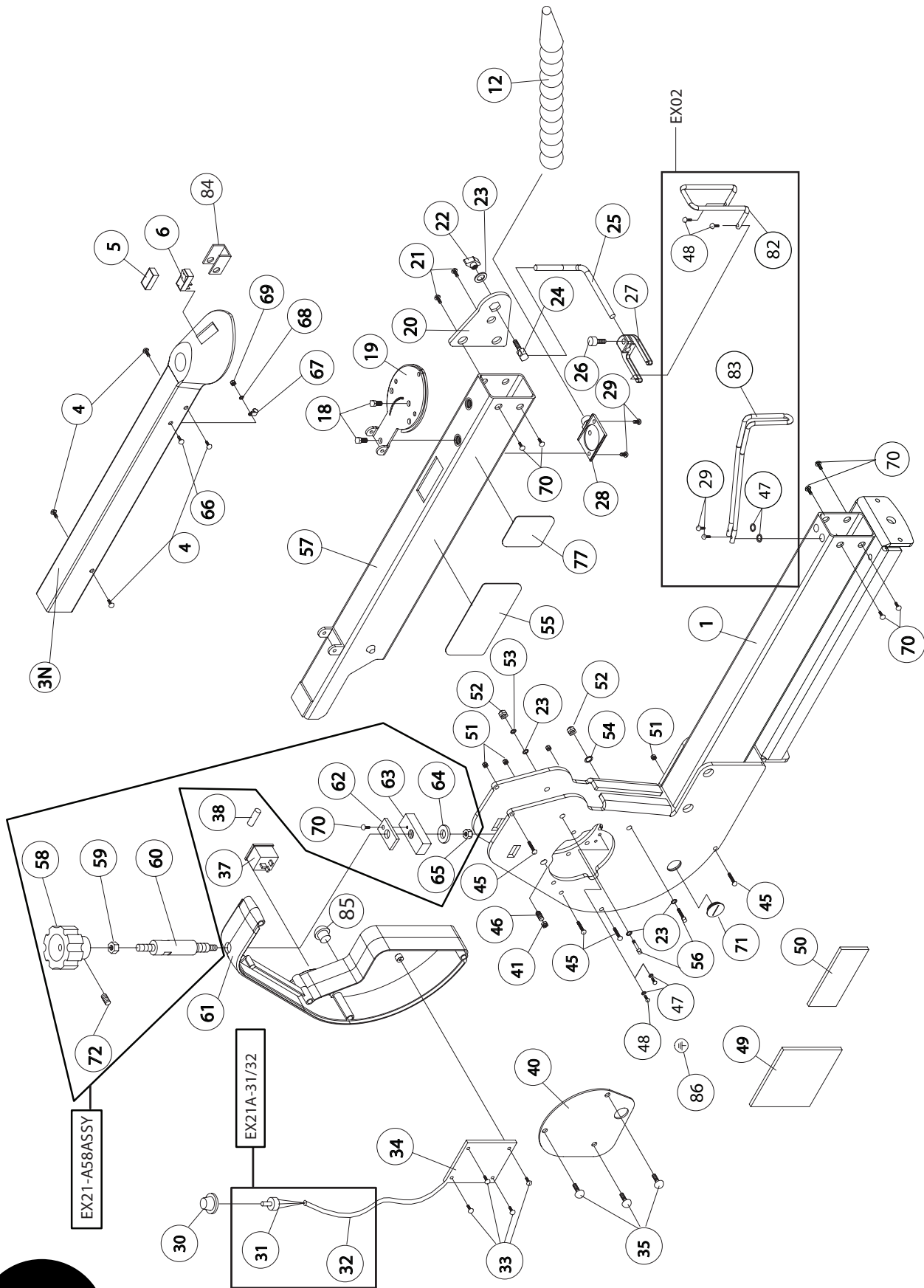



PARTS LIST - EX-16, EX-21, EX-30

REF. #	PART #	DESCRIPTION	SPECIFICATION	QTY
01	EX16-A78	MAIN BODY		1
	EX21-A01	MAIN BODY		1
	EX30-A01	MAIN BODY		1
03N	EX16-A79	TOP COVER		1
	EX21-A03N	TOP COVER		1
	EX30-A03	TOP COVER		1
04	EX21-A04	ALLEN SCREW	#10-32 X 1/4"	4
05	EX21-A05	SWITCH COVER		1
06	EX21-A06	SWITCH		1
12	EX21-A12	AIR NOZZLE		1
18	EX21-A18	BOLT	1/4-20 X 1/2"	2
19	EX21-A19	UPPER & LOWER TENSION PLATE		1
20	EX21-A20	HOLD DOWN MOUNT PLATE		1
21	EX21-A21	ALLEN SCREW	#10-32 X 3/8"	2
22	EX21-A22	HOLD DOWN CLAMP KNOB		1
23	EX21-A23	WASHER	1/4 X 16 X 1.8"	4
24	EX21-A24	HOLD DOWN CLAMP SCREW		1
25	EX21-A25	HOLD DOWN BAR		1
26	EX21-A26	CAP SCREW	#10-32 X 1/2"	1
27	EX21-A27	HOLD DOWN FORKS		1
28	EX21-A28	DUST BLOWER		1
29	EX02-03	TAP SCREW	#8-32UNF 3/8"	4
30	EX21-A30	VR KNOB		1
31	EX21-A31	VR		1
32	EX16-A81	CONTROL CABLE		1
	EX21-A32	CONTROL CABLE		1
	EX30-A32	CONTROL CABLE		1
	EX21A-31/32	VR WITH CONTROL CABLE		1
33	EX21-A33	SCREW	M4 X 8	4
34	EX21-A34	MOTOR CONTROL SET	CSA	1
35	EX21-A35	ALLEN SCREW	1/4-20 X 1/2 "	3
37	EX21-A37	LINE CORD SOCKET		1
38	EX21-A38	FUSE	3.15 AMP 20 X 5 MM GLASS FUSE	1
40	EX21-A40	GEAR COVER		1
41	EX21-A41	NUT	3/8 X T5.5	1
45	EX21-A45	ALLEN SCREW	#10-32 X 2-1/4"	4
46	EX21-A46	SCREW	3/8" X 5/8"	1
47	EX02-05	WASHER	#8	4
48	EX02-04	SCREW	#8-32 X 1/4"	4
49	EX21-A49	MOTOR LABEL		1
50	EX21-A50	WARNING LABEL		1
51	EX11-A51	NYLON NUT	#10-32	4
52	EX21-A52	NYLON NUT	1/4-20UNC	2
53	EX21-A53	LOCK WASHER	1/4"	1
54	EX21-A54	FLAT WASHER	1/4" (O.D.13)	1
55	EX21-A55	LABEL		2
56	EX21-A56	SCREW	1/4 X 2-1/2"	2
57	EX16-A80	UPPER ARM		1
	EX21-A57	UPPER ARM		1
	EX30-A57	UPPER ARM		1
58	EX21-A58	KNOB		1
	EX21-A58ASSY	UPPER ARM RISING KNOB ASSEMBLY		1
59	EX21-A59	NUT	M6	1
60	EX21-A60	ADJUSTING LEVER		1
61	EX21-A61	CONTROL BOX		1
62	EX21-A62	CROSS BLOCK RETAINER		1
63	EX21-A63	HOUSING CROSS BLOCK		1
64	EX21-A64	FLAT WASHER	M6 X 16 X 2	1
65	EX21-A65	NYLON NUT	M6	1
66	EX21-A66	ALLEN SCREW		1
67	EX21-A67	R FASTENER		1
68	EX21-A68	WASHER		1
69	EX21-A69	NYLON NUT		1
70	EX21-A70	ALLEN SCREW		7
71	EX21-A71	BUTTON		1
72	EX21-A72	SET SCREW		1
77	EX21-A77	LABEL		1
82	EX02-01	UPPER BLADE GUARD		1
83	EX02-02	LOWER BLADE GUARD		1
84	EX21-A84	SWITCH SAFETY GUARD		1
85	EX21-A85	STRAIN RELIEF		1
86	EX21-A86	GROUND LABEL		1

B

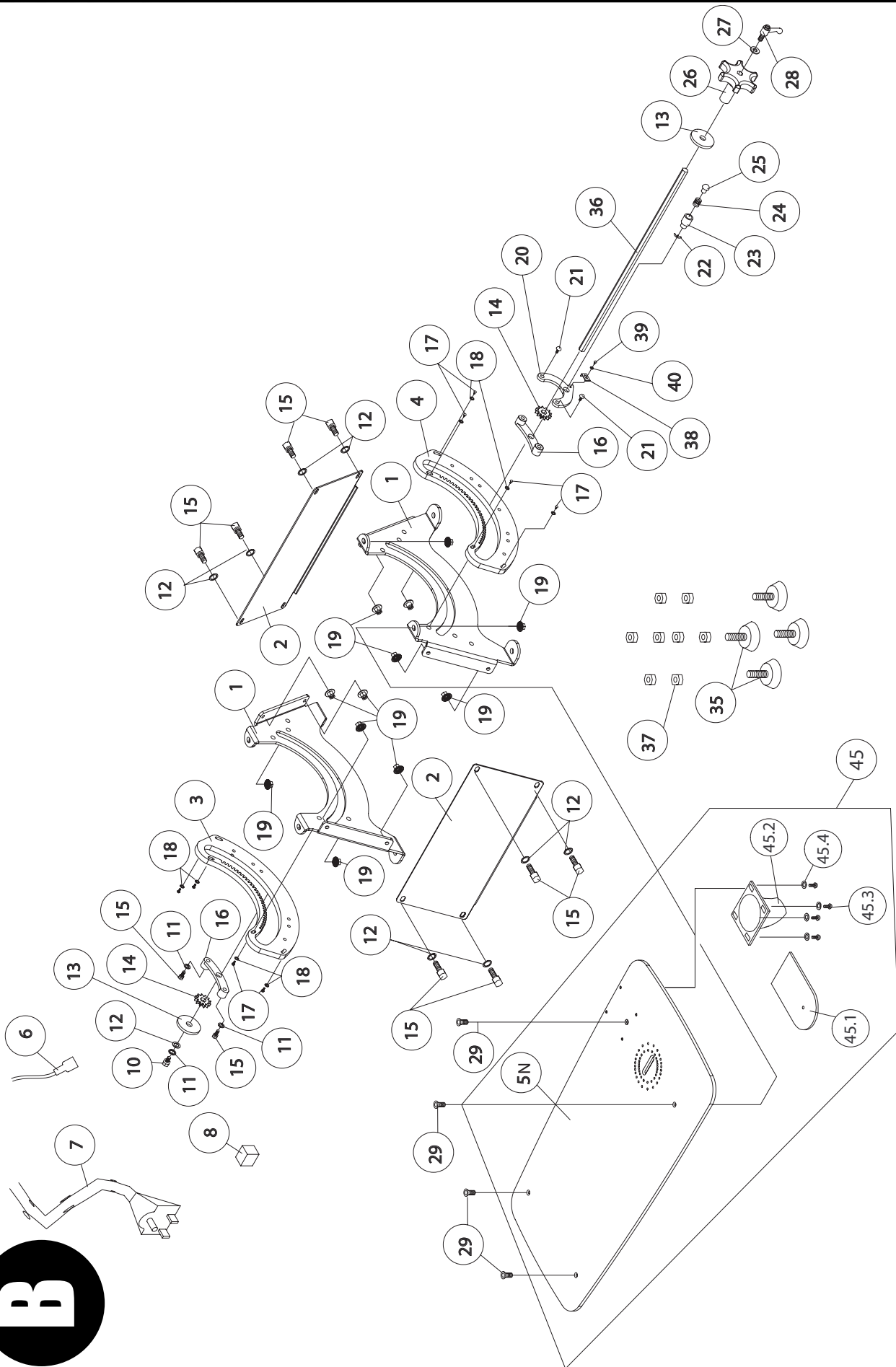

B**PARTS LIST - EX-16, EX-21, EX-30**

REF. #	PART #	DESCRIPTION	SPECIFICATIONS	QTY
01	EX21-B01	TRUNNION		2
02	EX16-B41	SIDE PANEL		2
	EX21-B02	SIDE PANEL		2
	EX30-B02	SIDE PANEL		2
03	EX21-B03	REAR TRUNNION PLATE		1
04	EX21-B04	FRONT TRUNNION PLATE		1
05N	EX16-B42N	TABLE (WITH HOLES)		1
	EX21-B05N	TABLE (WITH HOLES)		1
	EX30-B05N	TABLE (WITH HOLES)		1
06	EX21-B06	GROUND JUMPER		1
07	EX21-B07	POWER CORD	CSA	1
08	EX21-B08	SPONGE BLOCK		1
10	EX21-B10	SCREW	1/4-20UNC X 1/2	1
11	EX21-B11	LOCK WASHER	1/4	3
12	EX16-B43	WASHER		8
	EX21-B12	WASHER		9
	EX30-B12	WASHER	1/4	9
13	EX21-B13	BLADE TILT WASHER		2
14	EX21-B14	BLADE TILT DRIVE GEAR		2
15	EX16-B44	SCREW	1/4-20UNC X 3/4	10
	EX21-B15	SCREW	1/4-20UNC X 3/4	8
	EX30-B15	SCREW	1/4-20UNC X 3/4	10
16	EX21-B16	ANGLE FOLLOWER		2
17	EX21-B17	SCREW	#10-32 X 5/16	8
18	EX21-B18	WASHER	#10 X 12 X 1	8
19	EX21-B19	NUT	1/4-20UNC	12
20	EX21-B20	ANGLE INDICATOR		1
21	EX21-B21	ALLEN SCREW	1/4-20 X 1"	2
22	EX21-B22	E RING	ETW-3	1
23	EX21-B23	TILT DETENT BARREL		1
24	EX21-B24	SPRING		1
25	EX21-B25	DETENT PLUNGER		1
26	EX21-B26	TILT HANDLE		1
27	EX21-B27	WASHER	1/4 X 16 X 3	1
28	EX21-B28	BLADE TILT LOCKING LEVER		1
29	EX21-B29	FLAT HEAD SCREW	1/4-20 X 3/4	4
35	EX21-B35	LEVELING FOOT	3/8-16 X 1-1/4	4
36	EX16-B45	TILT LOCK DRAW ROD		1
	EX21-B36	TILT LOCK DRAW ROD		1
	EX30-B36	TILT LOCK DRAW ROD		1
37	EX21-B37	NUT	3/8-16UNC	8
38	EX21-B38	POINTER		1
39	EX21-B39	ROUND HEAD SCREW	M4 X 6MM	1
40	EX21-B40	WASHER	M4	1
45	EX16-DCT	DUST COLLECTOR TABLE KIT		1
	EX21-DCT	DUST COLLECTOR TABLE KIT		1
	EX30-DCT	DUST COLLECTOR TABLE KIT		1
45.1	EX21-B45.1	PLASTIC SHROUD		1
45.2	EX21-B45.2	DUST CHUTE		1
45.3	EX21-B45.3	ROUND HEAD SCREW	#8-32UNC-5/16	4
45.4	EX21-B45.4	WASHER	#8-32UNC	4

Notes

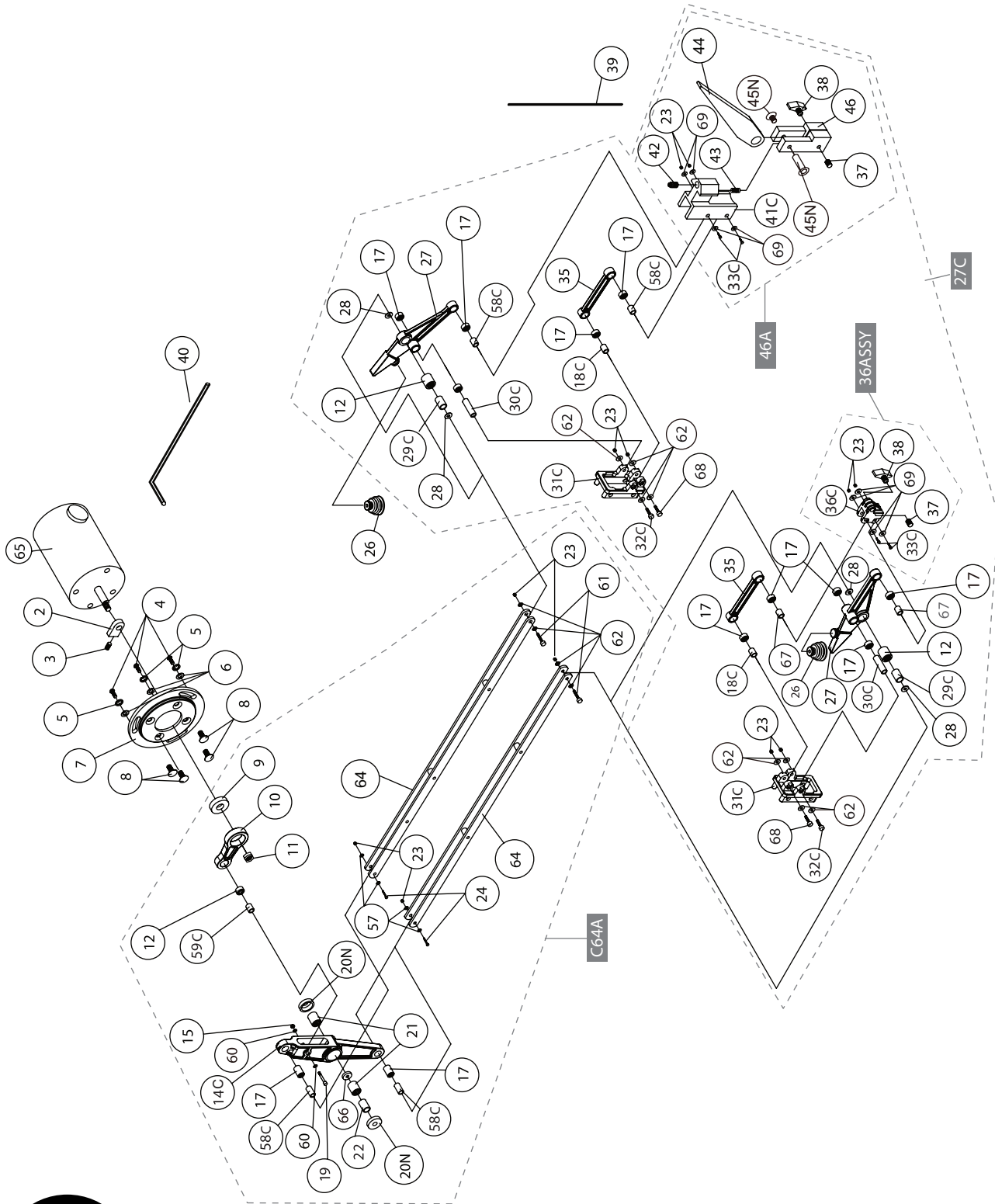



PARTS LIST - EX-16, EX-21, EX-30

REF. #	PART #	DESCRIPTION	SPECIFICATIONS	QTY
02	EX21-C02	BALANCE BLOCK		1
03	EX21-C03	SET SCREW	M6 X 6	1
04	EX21-C04	ALLEN SCREW	1/4-20 X 1/2	3
05	EX21-C05	LOCK WASHER	1/4	3
06	EX21-C06	FLAT WASHER	1/4 X 16 X 1.8	3
07	EX21-C07	MOTOR COVER PLATE		1
08	EX21-C08	SCREW	M6 X 16	4
09	EX21-C09	BEARING	608ZZ	1
10	EX21-C10	MOTOR CAM		1
11	EX21-C11	NUT	M8 X P1.25 LH	1
12	EX21-C12	BEARING	810	3
14C	EX21-C14C	ROCKER CAM		1
15	EX21-C15	LOCK NUT	M5	1
17	EX21-C17	BEARING	0609	10
18C	EX21-C18C	BEARING INNER SLEEVE (SHORT)	Ø6.03 X 21MM	2
19	EX21-C19	CAP SCREW	M5 X 28	1
20N	EX21-C20N	BEARING COVER		2
21	EX21-C21	BEARING	1412	2
22	EX21-C22	MAIN ROCKER PIVOT	Ø14.04 X 35.5MM	1
23	EX21-C23	NUT	M4	12
24	EX21-C24	CAP SCREW	M4 X 25	2
26	EX21-C26	AIR PUMP BELLOWS		2
27	EX21-C27	FRONT ROCKER		2
27C	EX21-C27C	UPPER AND LOWER ROCKER ASSEMBLY		1
28	EX21-C28	WASHER	M8 X 15 X 0.6	4
29C	EX21-C29C	INNER BEARING SLEEVE - FRONT ROCKER	Ø8.03 X 18.40MM	2
30C	EX21-C30C	BEARING INNER SLEEVE (LONG)	Ø6.03 X 37MM	2
31C	EX21-C31C	ROCKER MOUNT		2
32C	EX21-C32C	CAP SCREW	M4 X 45	2
33C	EX21-C33C	CAP SCREW	M4 X 25	4
35	EX21-C35	STRUT		2
36C	EX21-C36C	BLADE CHUCK		1
36ASSY	EX21C-36ASSY	BLADE CHUCK BOTTOM ASSEMBLY		1
37	EX21-C37	SET SCREW	M6X8	2
38	EX21-C38	BLADE CLAMP THUMB SCREW		2
39	EX21-C39	BLADE		1
40	EX21-C40	ALLEN KEY	3MM	1
41C	EX21-C41C	CLAMP BRACKET		1
42	EX21-C42	SET SCREW	1/ 4-20UNC	1
43	EX21-C43	SPRING		1
44	EX21-C44	TENSION LEVER (FOR EX-16 & EX-21)	5MM	1
	EX30-C44	TENSION LEVER (FOR EX-30)	7MM	1
45N	EX21-C45	SCREW POST	5 X 18	1
46	EX21-C46	SLIDING BRACKET		1
46A	EX21-C46A	UPPER BLADE TENSION ASSEMBLY (FOR EX-16 & EX-21)		1
	EX30-C46A	UPPER BLADE TENSION ASSEMBLY (FOR EX-30)		1
57	EX21-C57	WASHER	M4 X 10 X 1	4
58C	EX21-C58C	INNER BEARING SLEEVE (LONG)	Ø6.02 X 16.50MM	4
59C	EX21-C59C	BEARING INNER SLEEVE	Ø8.03 X 21.50MM	1
60	EX21-C60	WASHER	M5	2
61	EX21-C61	CAP SCREW	M4 X 27	2
62	EX21-C62	WASHER	M4 X 14 X 1	12
64	EX16-C64	DRIVE LINK ASS'Y (FOR EX-16)		2
	EX21-C64	DRIVE LINK ASS'Y (FOR EX-21)		2
	EX30-C64	DRIVE LINK ASS'Y (FOR EX-30)		2
64A	EX16-C64A	COMPLETE DRIVE LINK ASS'Y (FOR EX-16)		2
	EX21-C64A	COMPLETE DRIVE LINK ASS'Y (FOR EX-21)		2
	EX30-C64A	COMPLETE DRIVE LINK ASS'Y (FOR EX-30)		2
65	EX21-C65	MOTOR		1
66	EX21-C66	SPACER		1
67	EX21-C67	BEARING INNER SLEEVE (SHORT)	Ø6.03 X 16MM	2
68	EX21-C68	CAP SCREW	M4 X 30	2
69	EX21-C69	WASHER	M4 X 8 X 1	8

IMPORTANT: When ordering replacement parts, always give the model number, serial number of the machine and part number. Also a brief description of each item and quantity desired.

MODELS EX-16 / EX-21 / EX-30

(MODEL #EX-21 SHOWN)

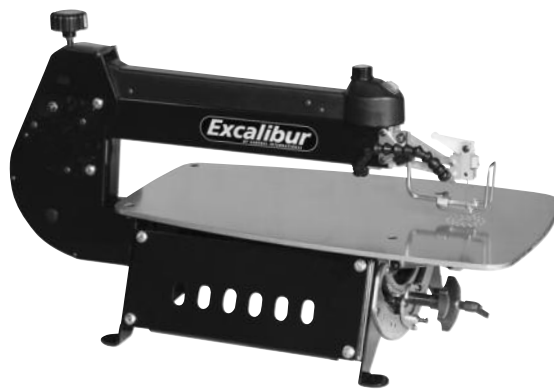

8360 Champ-d'Eau, Montreal (Quebec) Canada H1P 1Y3

Tel.: (514) 326-1161

Fax: (514) 326-5565 - Parts & Service / Fax: (514) 326-5555 - Order Desk

orderdesk@general.ca
www.general.ca

Follow us:

