

# brent<sup>®</sup>



OWNER'S MANUAL



FOR ALL BRENT<sup>®</sup> POTTER'S WHEEL MODELS

## WELCOME

Congratulations on your purchase of a brent® Potter's Wheel. We trust that you will be pleased with your decision and enjoy your new wheel for years to come!

**Please read the enclosed safe operation, maintenance, and warranty information carefully.**

## DELIVERY INSPECTION | PACKAGE CONTENTS



Before signing the delivery receipt, thoroughly inspect your package. If merchandise is damaged, please make notation of the damage on delivery receipt, stating that you request an inspection by a qualified damage claim inspector. Follow up with a call to the delivery carrier, making an appointment for the inspection. At this time notify AMACO/brent as to the extent of the damage and you will be informed upon the procedures necessary for filing a claim with the freight company.

**Do not attempt to operate the wheel if damaged.**

Package Contents:



[ 1 - Wheel and Foot Pedal ]



[ 1 - Splash Pan: two halves ]

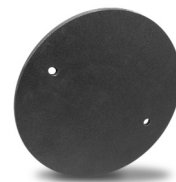

[ 1 - Plasti-bat ]

# IMPORTANT SAFETY INSTRUCTIONS

## Read All Instructions

- Do not overload the wheel head with clay or force it to stop, as this will shorten the life of the motor. Maximum clay weight should not exceed recommended weight for your wheel.
- Do not plug power cord into an extension cord. Plug directly into electrical wall outlet.
- Foot pedal must be fully depressed backwards “off” before turning wheel on.
- When cleaning the wheel, inspecting parts, and between periods of use, always turn off the on/off switch and confirm that the power indicator light is off. Then unplug the wheel from its power source.
- Take care with long hair, jewelry, and loose fitting clothing. Such items may get caught in the moving wheel head causing damage or injury.
- Keep tools and small parts out of reach of small children.
- Do not leave wheel running unattended.
- Repairs and modifications should be made by a qualified technician only. Should you need clarification or help troubleshooting before calling a technician, call AMACO/brent first at 800-925-5195, ext. 1303 for help and technical support.
- Stop operation of the wheel if you see or smell smoke, or if you hear unusual noises. Then turn off power, unplug power cord from outlet, and call brent® Repair for assistance.
- Do not remove the control box and panel covers when the wheel is plugged into power. Doing so makes the internal parts vulnerable to damage.
- Do not attempt to move or hold the wheel during operation, or while the power is on as this could cause serious injury.
- Place the wheel on a flat, even surface away from other objects.
- Equipment must be lifted by two people, never attempt to lift the wheel by yourself.
- Never operate the wheel with the belt guard removed.
- Disconnect the power supply whenever conducting repair.
- The socket outlet must be in the vicinity of the machine and under immediate supervision of the service personnel at all times.
- Do not let the wheel stand in water.
- Plug the wheel into a grounded (3-prong) 110 or 230 volt AC outlet, depending on your wheel’s power configuration. If you do not have grounded outlets available and have to use an adaptor, make certain that you connect the green wire from the adaptor to a suitable ground.

**Note: It is not safe to operate electrical equipment around water if it is not grounded.**

## SAVE THESE INSTRUCTIONS

## brent® *ie* and *ie-x* Potter's Wheels Leg Installation

Once you've opened the carton and carefully removed your wheel:

The wheel is shipped in its table-top configuration and comes equipped with a 9-foot cord for versatility. Follow the instructions below for floor-model configuration.

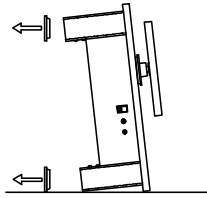
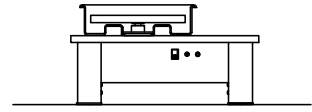

1. Position the wheel on its back edge with the bottom facing you. Exercise caution not to allow the wheel to tip over as it may damage the wheel head assembly.
2. Remove the end caps from the leg stubs of the wheel (this allows the legs to be inserted into the leg stubs). Remove the foot pedal and the three (3) legs from the attached box.

3. Insert a leg into one of the two bottom leg cylinders of the main assembly until fully seated. Using the 5/16" allen wrench (provided) turn both set screws until they make contact with the leg, then tighten each screw another 1/4 turn.

4. Repeat step 3 for the remaining two legs inserting the top leg last.

Note: Each leg comes with a cap plug installed in the bottom. They may loosen some during shipping. Tap them lightly with a hammer to reset.

5. With the legs fully seated, the wheel is at the industry standard height. If you prefer, you may raise the wheel height by loosening the set screws and pulling the legs out to the desired length. Then retighten the set screws as described in step 3.

Note: Ensure that all three (3) legs are set to the same length so the wheel will sit level.

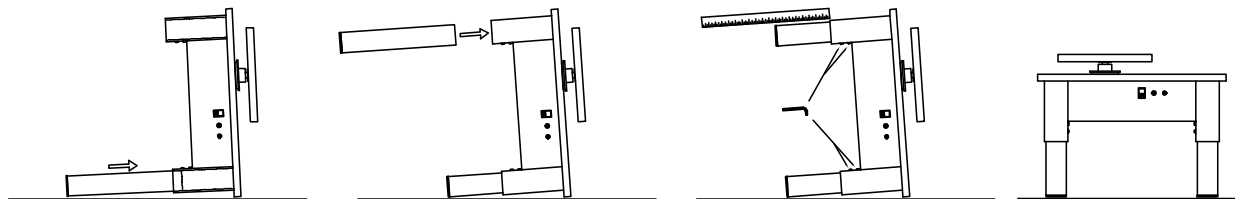

6. The wheel has an on/off switch, a fuse, and on some models, a reversing switch located on the right side of the wheel. Make sure the foot pedal is in the off position before turning your power switch on.

7. Occasionally, due to minor voltage variations, you may need to adjust the foot pedal to achieve an optimal calibration to your electrical environment. (see Troubleshooting, pages 7-8)

## SPLASH PAN INSTALLATION INSTRUCTIONS

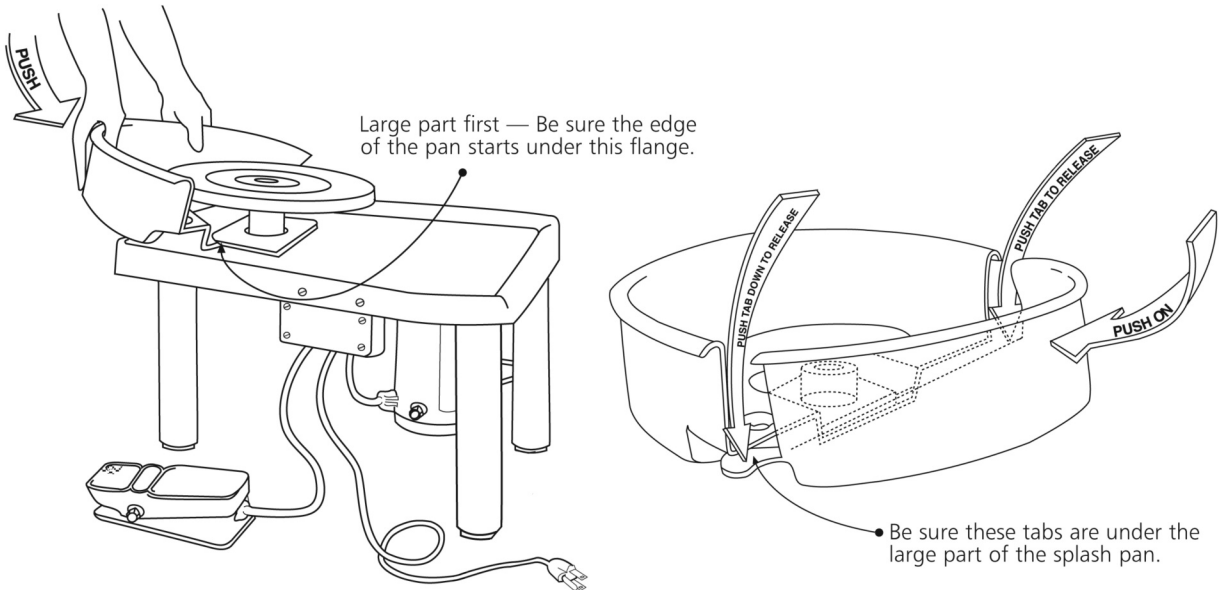

## OPERATION

Tip the foot pedal towards you in the "off" position and toggle the on/off switch into the "on" position. The pilot light will come on indicating that the solid state circuit that controls the motor is receiving power. With the foot pedal tipped back, the wheel head should not rotate. As the foot pedal is pushed forward, the speed should increase smoothly, up to a maximum of 240 rpm. If the wheel does not turn off with the foot pedal back, or does not run fast enough, see Troubleshooting on page 7. **All wheels except the ie model are reversible.** If you wish to reverse the direction, tip the foot pedal toward you in the "off" position. When the wheel stops, move the FWD/REV toggle switch to either Forward or Reverse.



**Note:** When starting up your wheel for the first time, the wheel may have a slight "thump" sound. This is normal and is a result of the rubber drive belt being held in the same position since manufacturing and should go away within 10 or 15 minutes of use.

## CARE

With proper care and maintenance, brent® wheels have been known to be in service for over 30 years. To insure this kind of dependability from your brent® wheel, please follow these simple care and maintenance instructions.

- Turn off and unplug wheel when not in use.
- To ensure maximum brush life, always allow the motor to come to a complete stop before changing directions of the wheel head.
- Clean wheel after every use by removing splash pan and emptying contents into slop bucket. Sponge down table and legs.
- Clean floor of any surrounding water and wet clay.
- Store foot pedal on wheel table when not in use. In addition, when mopping studio floors, foot pedals should be placed on the table top of the pottery wheel.
- Always clean wheel with a damp sponge and water, do not use solvents and do not use a hose.
- Do not let wheel stand in water or slop.
- Store in a dry space away from outdoor elements. If placing the wheel into storage, it might be beneficial to pull your motor brushes from the motor with the wheel disconnected from power, in order to avoid problems that could arise otherwise.
- Keep the serial number and the date of purchase in a safe place: you will need this information if you ever need service or want to make modifications to the wheel.

## MAINTENANCE

To ensure correct belt tension and maximum belt life, all our belt drive wheels come equipped with automatic belt tensioning devices. The spring tensioner will eliminate having to tighten the belts. It's not necessary to release the spring tensioner when removing the belt, simply roll the belt off the pulley. Check belts every five years for wear as the rubber will break down faster in some climates. To replace the belt, fit it on the small pulley first and then turn it onto the larger one.

Motor brushes should be replaced every 5000 hours of operation. This equates to a standard use of 4 hours per day, 5 days per week for 5 years.

Please contact AMACO/brent or your local pottery dealer when your brushes require replacing to receive the necessary brushes and installation instructions. Please be sure to include the serial number of your wheel and make of motor so that the correct brushes for your wheel can be obtained.



## TROUBLESHOOTING

The following is a list of the most common concerns that may be experienced while using your brent® potter's wheel. Most of these difficulties occur as a result of normal "wear and tear" and can be solved with ease. Our brent® wheels have up to a ten year warranty on in-house service and parts. If you have any questions or need to order replacement parts, contact the AMACO/brent Technical Support Department at 800-374-1600.

**Note: Always unplug your wheel when it is not in use to protect against power surges and lightning storms.**

### **Wheel head still rotates when pedal is off:**

1. Remove bottom of pedal. Check plastic arm to see if it is tight on the bolt that runs through it. If it is not, push plastic arm to the bottom of pedal and tighten the set screw in the base of the arm. [ Fig A ]
2. Turn the blue "LO" disc clockwise until wheel head stops rotating. [ Fig B ]

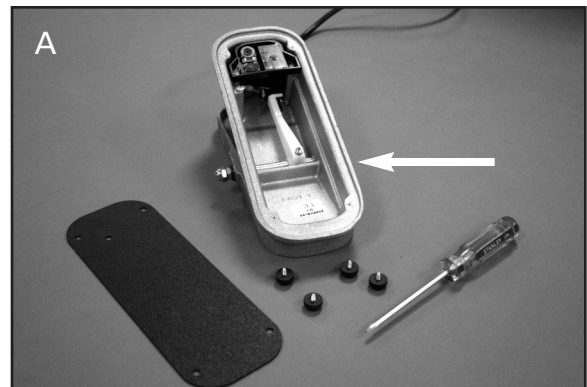

### **Wheel does not rotate even though power is on:**

1. Disconnect the power supply.
2. Check the fuse and replace if blown. (See page 15).
3. If there is power to the control box and the fuse is fine, please call brent® Repair for assistance.



### **Belt is rubbing against the belt guard (not applicable for ie models):**

1. Lean the wheel back so that it is lying securely on its back.
2. Loosen the two bolts that hold the guard in place. [ Fig C ]
3. Adjust the guards until rubbing stops.
4. Tighten bolts.
5. If problem persists, please call brent® Repair for assistance.

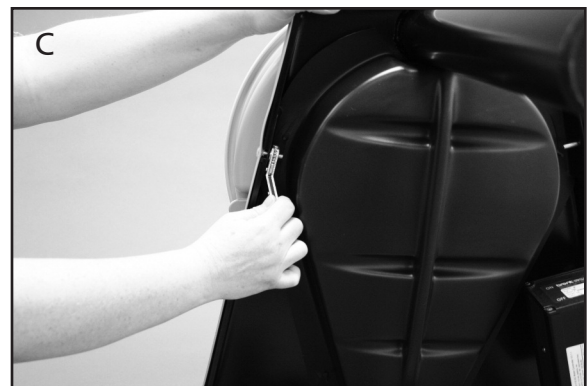

**Wheel head is not rotating, but the motor is running:**

The belt is off its pulleys or has broken.

1. Disconnect the power supply.
2. Lean the wheel back so it is resting securely on its back legs.
3. Remove belt guard.
4. Place belt in middle grooves of small pulley on motor.
5. Start belt on large pulley, rotating large pulley until belt is on. [ Fig D ]
6. Turn wheel on and test to make sure that the belt stays on. (If belt continues to fall off, call brent® Repair for assistance.)
7. Reinstall the belt guard.



**Wheel head rotates too fast or too slow:**

1. Turn foot pedal over and remove the bottom plastic cover from the pedal.
2. Locate the red disc, this is the "HI" speed adjustment.
3. Using a small standard screwdriver, rotate the red disc clockwise to increase the speed, or counter-clockwise to decrease the speed.
4. Any adjustments to the red disc may result in having to make an adjustment to the blue disc. If you increase the overall speed of the wheel, you may have to turn the blue disc clockwise to make the wheel stop when the pedal is moved to the off position, If the wheel speed is decreased, you may have to turn the blue disc counter-clockwise to increase the range of motion when the foot pedal is moved to the off position.



**Note:** The discs are very sensitive and will require very little movement, 1 to 5 degrees at a time. The wheel be can on and rotating while making this adjustment to ensure that the start point is at the desired speed. **Please note that if your screwdriver touches the silver tabs between the red and blue discs, while the wheel is connected to power, this could result in a blown circuit board.**



# brent® b, c, cxc, ex Parts Diagram

Match circled numbers on this page to item numbers on pages 10-11 for part description.

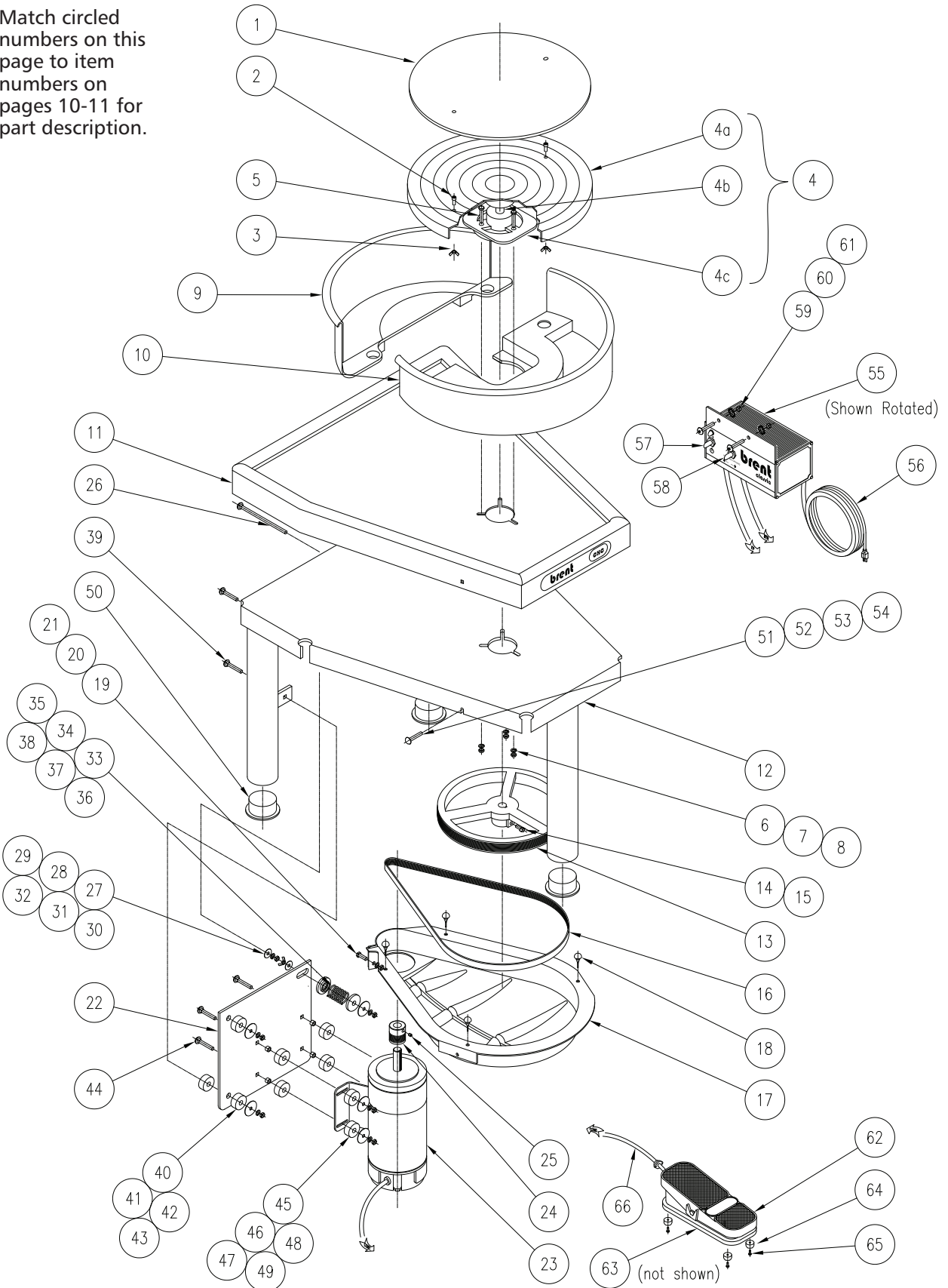

## Parts List for brent® Wheels B, C, CXC, EX and 16

Item #	Qty.	Part #	Description
		32331K for Models B, 16	
1	1	32333M for C, CXC & EX Models	Plasti-Bat
2	2	22135X	Bat Pin
3	2	Item 2 & 3 sold as set	Bat Pin Wing Nut
		22012M for B, 16	
4	1	22017T for C, CXC & EX Models	Wheel Head Assembly
4a	1	4a, 4b & 4c sold as assembly only see item 4	Wheel Head
4b	1	4a, 4b & 4c sold as assembly only see item 4	Wheel Head Shaft & Bearing
4c	1	4a, 4b & 4c sold as assembly only see item 4	Bearing Housing
5	3	5/16-18 x 1 1/4 Hex Bolt	Wheel Head Mounting Bolt
6	3	5/16 Flat Washer	Wheel Head Mounting Flat Washer
7	3	5/16 Lock Washer	Wheel Head Mounting Lock Washer
8	3	5/16-18 Hex Nut	Wheel Head Mounting Nut
9	1	22281F	Splash Pan Front
10	1	Items 9 & 10 sold as a set	Splash Pan Back
11	1	22279D	Table Top Plastic
12	1	22426W	Steel Frame and Legs
13	1	22048J	Large Drive Pulley
14	1	5/16-18 x 5/8 Square Head	Drive Pulley Lock Bolt
15	1	3/16 x 1 1/4 Key Stock	Drive Pulley Shaft Key
16	1	22926W	Drive Belt
17	1	22570W	Belt Guard
18	4	22307N	Belt Guard Vibration Snubber
19	1	1/4-20 x 3/4 Hex Bolt	Belt Guard Bolt
20	1	1/4 Lock Washer	Belt Guard Lock Washer
21	1	1/4-20 Hex Nut	Belt Guard Nut
22	1	08671C	Motor Mounting Plate
		22228N for B, 16 Wheels    22767G for C Wheel	
23		22227N for CXC Wheel    22786F for EX Wheel	Motor
24	1	22637V (set screw included)	Motor Drive Pulley (Small Pulley)
		1/4-20 x 1/4 Allen Set Screw (included with motor	
25	1	pulley part # 22637V)	
26	1	5/16-18 x 5 Carriage Bolt	Drive Belt Tension Bolt
27	1	5/16 Flat Washer	Drive Belt Tension Bolt Flat Washer
28	1	5/16 Lock Washer	Drive Belt Tension Bolt Lock Washer
29	1	5/16 Hex Nut	Drive Belt Tension Bolt Nut
30	1	5/16-18 Wing Nut	<i>Items 30, 31 &amp; 32 Used for shipping only</i>
31	1	5/16 Lock Washer	<i>Items 30, 31 &amp; 32 Used for shipping only</i>
32	1	5/16 Flat Washer	<i>Items 30, 31 &amp; 32 Used for shipping only</i>
33	1	22286L Items 33 & 35 sold as set	Tension Spring Guide Rear
34	1	22178B	Tension Spring
35	1	22286L Items 33 & 35 sold as set	Tension Spring Guide Front
36	1	5/16 Fender Washer	Drive Belt Tension Bolt Fender Washer
37	1	5/16 Lock Washer	Drive Belt Tension Bolt Lock Washer
38	1	5/16-18 Hex Nut	Drive Belt Tension Bolt Hex Nut
39	2	1/4-20 x 2 Carriage Bolt	Motor Mounting Plate Bolt
40	4	22306M	Motor Mounting Plate Bushing
41	2	1/4 Fender Washer	Motor Mounting Plate Fender Washer
42	2	1/4 Lock Washer	Motor Mounting Plate Lock Washer
43	2	1/4-20 x 2 Carriage Bolt	Motor Mounting Bolt

*Parts list continued on page 12.*

## Parts List for brent® Wheels B, C, CXC, EX and 16 continued

Item #	Qty.	Part #	Description
45	4	Used for Manufacturing Only	Motor Mounting Bolt Retainer
46	8	22306M	Motor Mounting Bushing
47	4	1/4 Fender Washer	Motor Mounting Fender Washer
48	4	1/4 Lock Washer	Motor Mounting Lock Washer
49	4	1/4-20 Hex Nut	Motor Mounting Hex Nut
50	3	22307N	Frame Leg Plug
51	2	1/4-20 x 3/4 Hex Bolt	Belt Guard Bolt
52	2	1/4 Lock Washer	Belt Guard Flat Washer
53	2	1/4 Flat Washer	Belt Guard Lock Washer
54	2	1/4-20 Hex Nut	Belt Guard Hex Nut
55	1	22906Y for Models B, 16 22907A for C Model 22908C for CXC Model 22912F for EX Model	Classic Controller
56	1	Please call for prices and availability	Power Cord for Classic Controller
57	1	Please call for prices and availability	Power Switch for Classic Controller
58	1	Please call for prices and availability	Reversing Switch Classic Controller
59	2	1/4-20 x 1 Phillips Head Machine Screw	Controller Mounting Bolt
60	2	1/4 Star Washer	Controller Mounting Star Washer
61	2	1/4-20 Nylok Nut	Controller Mounting Nylok Nut
62	1	22035R	Foot Pedal Complete
63	1	22278C	Foot Pedal Cover
63	1	22858R	Electric Sub-assembly for Foot Pedal
63	1	22881S	Foot Pedal Tension Hardware & Arm
64	4	22273W (Mtg. Screws Included)	Foot Pedal Foot
65	4	6/32 X 3/8 Phillips Head Machine Screw	Foot Pedal Foot Mounting Screw
66	1	08420B	Foot Pedal Cord

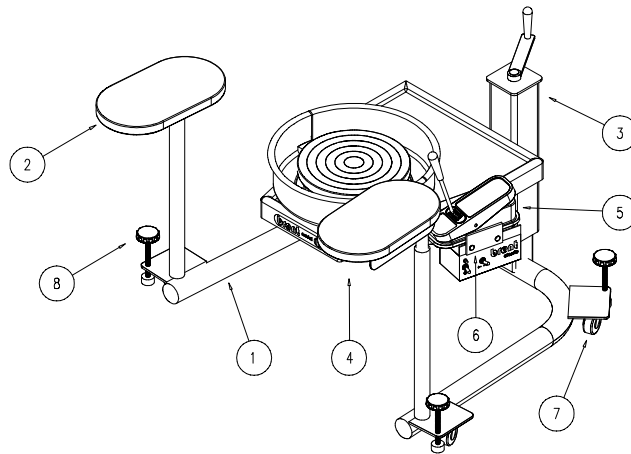

## Additional Parts for brent® Wheel 16

Item #	Qty.	Part #	Description
1	1	22508S	Frame, 16 Complete
2	2	22851G	Arm Supports
3	1	22849F	Crank Assembly
4	1	22935H	Belt Guard
5	1	22823B	Foot Lever with Lever
6	1	22818T	Foot Pedal Mounting Bracket
7	4	22847C	Caster
8	4	22846D	Adjusting Foot

# brent® ie, ie-r, ie-x Parts Diagram

Match circled numbers on this page to item numbers on page 13 for part description.

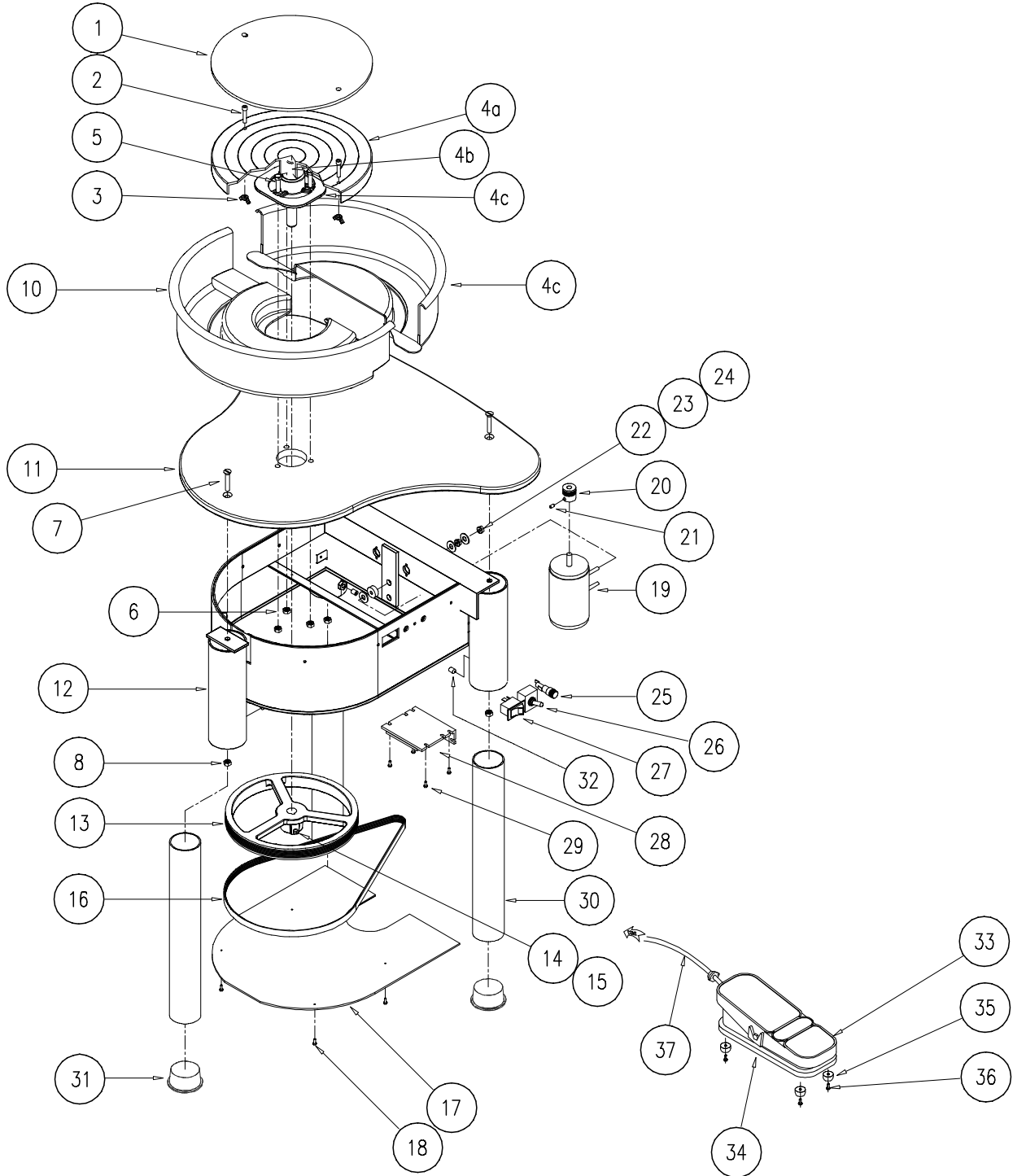

## Parts List for brent® Wheels ie, ie-r, ie-x

Item #	Qty.	Part #	Description
		32331K for IE & IE-R Models	
1	1	32333M for IE-X Models	Plasti-Bat
2	2	22135X	Bat Pin
3	2	Item 2 & 3 sold as set	Bat Pin Wing Nut
		22012M for IE & IE-R Models	
4	1	22017T for IE-X Models	Wheel Head Assembly
4a	1	4a, 4b & 4c sold as assembly only see item 4	Wheel Head
4b	1	4a, 4b & 4c sold as assembly only see item 4	Wheel Head Shaft & Bearing
4c	1	4a, 4b & 4c sold as assembly only see item 4	Bearing Housing
5	3	5/16-18 x 1 1/2 Hex Bolt	Wheel Head Mounting Bolt
6	3	5/16-18 Flange Nut	Wheel Head Mounting Nut
7	3	5/16-18 X 1 3/4 Flat Head Slotted Machine Screw	Table Top Mounting Bolt
8	3	5/16-18 Flange Nut	Table Top Mounting Nut
9	1	22281F	Splash Pan Front
10	1	Items 9 & 10 sold as a set	Splash Pan Back
11	1	08024R	Table Top IE Black
12	1	08209A	Steel Frame
13	1	22048J	Large Drive Pulley
14	1	5/16-18 x 5/8 Square Head	Drive Pulley Lock Bolt
15	1	3/16 x 1 1/4 Key Stock	Drive Pulley Shaft Key
16	1	22766F	Drive Belt
17	1	08770R	Belt Guard
18	4	1/4-20 x 3/4 Hex Bolt	Belt Guard Screws
	1	22689H for IE & IE-R Wheel	
19	1	22765E for IE-X Wheel	Motor
20	1	22626X (set screw included)	Motor Drive Pulley (Small Pulley)
		1/4-20 x 1/4 Allen Set Screw (included with motor pulley part # 22637V)	
21	1		
22	6	1/4 Fender Washer	Motor Mounting Fender Washer
23	4	5/16-18 Flange Nut	Motor Mounting Flange Nut
24	2	22306M	Motor Mounting Bushing
25	1	22134W	Fuse Holder
26	1	08780C	Reversing Switch (IE-R & IE-X only)
27	1	22117A	Power Switch
28	1	22140R	PCB Controller
29	4	#6 1/2" Pan Head Phillips Screw	PCB Controller Screws
30	3	22822A	IE Leg
31	3	22695P	Frame Leg Plug
32	6	6-20, 1/2" Self-Tapping Screw	Leg Extension Set Screws
33	1	22035R	Foot Pedal complete
34	1	22278C	Foot Pedal Tension Hardware & Arm
35	4	2273W (Mtg. Screws Included)	Foot Pedal Foot
36	4	6/32 X 3/8 Phillips Head Machine Screws	Foot Pedal Foot Mtg. Screw
37	1	08420B	Foot Pedal Cord



## Wheel Specifications

Model	HP	Wheel Head	Slow Burn Fuse Size	Voltage	Part Number
ie	1/4	12"	6 amp	120	22833M
			6 amp	230	22800X
ie-r	1/4	12"	6 amp	120	22897M
ie-x	1/3	14"	6 amp	120	22900R
			6 amp	230	22901P
B	1/2	12"	20 amp	120	22604E
			25 amp	230	22606G
C	3/4	14"	20 amp	120	22608J
			25 amp	230	22610L
CXC	1	14"	20 amp	120	22727G
			25 amp	230	22728H
EX	1 1/2	14"	25 amp	120	22573A
16	1/2	12"	20 amp	120	22666E
			25 amp	230	22613P

## Fuse Location

### USE SLOW BURN FUSES ONLY

The ie series wheels have the fuse located on the side of the wheel, near the power switch. To replace the fuse of a B, C, CXC, EX, and/or No. 16 Wheel, refer to the diagram below.

**CAUTION: UNPLUG THE WHEEL PRIOR TO REPLACING THE FUSE!**

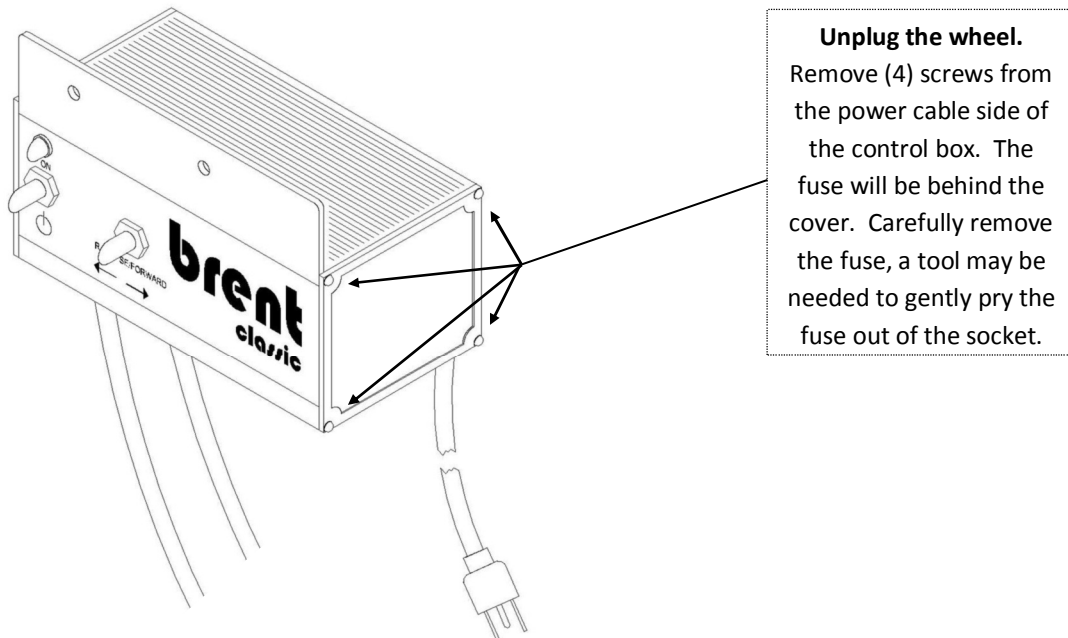

# WARRANTY INFORMATION

## TERMS

The brent® potter's wheels warranty is limited to defects in materials and workmanship during the manufacturing process for up to ten years (see chart below).

- Ultimate determination for validation of warranty claims is at the discretion of AMACO/brent.
- All warranty work must be performed by an authorized brent® dealer or by the manufacturer to maintain the warranty. Any work done by someone other than an authorized dealer or the manufacturer will void this warranty.
- Warranty is non-transferable.
- Retain original purchase receipt. You will need this along with model number and serial number to obtain warranty service.
- The warranty is in effect from the date of purchase and is as follows:

EQUIPMENT	WARRANTY LENGTH
brent® b, c, cxc, EX, j, ej, 16 Potter's Wheels purchased after 01/01/2009	10 Years
brent® ie, ie-r, ie-x Potter's Wheels purchased after 01/01/2011	5 Years

## EXCLUSIONS

Your AMACO/Brent Warranty will be void if any of the following occur:

- The warranty period has expired.
- Repair or service is done by an unauthorized dealer.
- Damage due to abuse and/or misuse; including but not limited to improper installation, rough handling, improper storing.
- Shipping damage.
- Damage or failure due to acts of God such as, fire, flood, electrical storms, etc.
- Use other than for intended.
- Normal wear and tear on parts such as wheel heads and belts.
- Modifications to the unit in any manner.

## REPAIR INSTRUCTIONS

If you have a problem with your brent® wheel within the warranty period, choose one of the following options:

1. Contact the dealer from which you purchased the wheel. If they are an authorized dealer that offers parts and service, they can handle the repair or replacement. Parts and labor will be covered for valid warranty claims.
2. If the dealer is unauthorized to perform the repair or unable to correct the problem, call AMACO/brent customer service, (800) 374-1600 or email [technicalsupport@amaco.com](mailto:technicalsupport@amaco.com). Please have the model and serial number ready when you call or include them in the email. The serial number, located on a sticker underneath the wheel, will help the technician know when your wheel was built to better assist you (see photos below). Parts and labor will be covered for valid warranty claims.



Models B, C, CXC, EX, 16

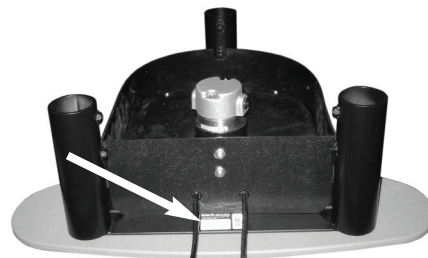

Models ie, ie-r, ie-x

You may be asked to send the defective equipment or part(s) in for inspection. The serial number of the wheel being repaired must accompany the defective parts for the warranty to be honored. Also include a note describing the nature of the problem. This will save the technician time since many problems are intermittent and may not show up immediately. Parts and labor will be covered for valid warranty claims.

If it is necessary to ship wheel or parts to AMACO/brent for inspection, repair or replacement, the technician will explain how to return the defective item(s) and whether it should be sent prepaid. For your protection, insure all items shipped.

## Accessories For Your brent® Wheel



### **brent® Booties**

Set of three Leg risers to raise your wheel 2" or 4". Product No. 22785E



### **brent® Workstation**

Attaches to rear legs of brent® wheels. Holds tools and other supplies while throwing. Height adjustable. Product No. 22878N



### **brent® Leg Extensions**

New, improved design. Legs adjust from 32½" to 37½" in ½" increments. Product No. 22827X



### **brent® WorkTables**

Two sizes: 16" x 10" or 1" x 10". Each attaches to rear legs of brent® wheels and can be rotated or raised/lowered for custom fit. Available individually or as a set. Product No. 22879P



### **Plast-i-bat®**

Easy to clean, waterproof, won't swell or shrink, made of thick, rigid plastic. 8 sizes; with and without bat pin holes.



### **brent® Black Splash Pan**

Same sturdy material and easy to clean as the original gold splash pan that comes with all brent® wheels. Product No. 22930B



### **brent® Batmobile**

Stores up to 90 bats (14" diameter), easy to assemble, 4" locking rubber casters, welded joints for stability. Product No. 22066J



AMERICAN ART CLAY CO., INC.  
6060 Guion Road, Indianapolis, IN 46254-1222 USA  
(800) 374.1600 • [www.amaco.com](http://www.amaco.com)

Amaco® and Brent® are registered trademarks of American Art Clay Co., Inc.